



EN 1994 - Eurocode 4: Design of composite steel and concrete structures

Composite Slabs

Stephen Hicks



Welded mesh reinforcement for crack control, transverse load distribution and fire resistance

Concrete cast *in situ*

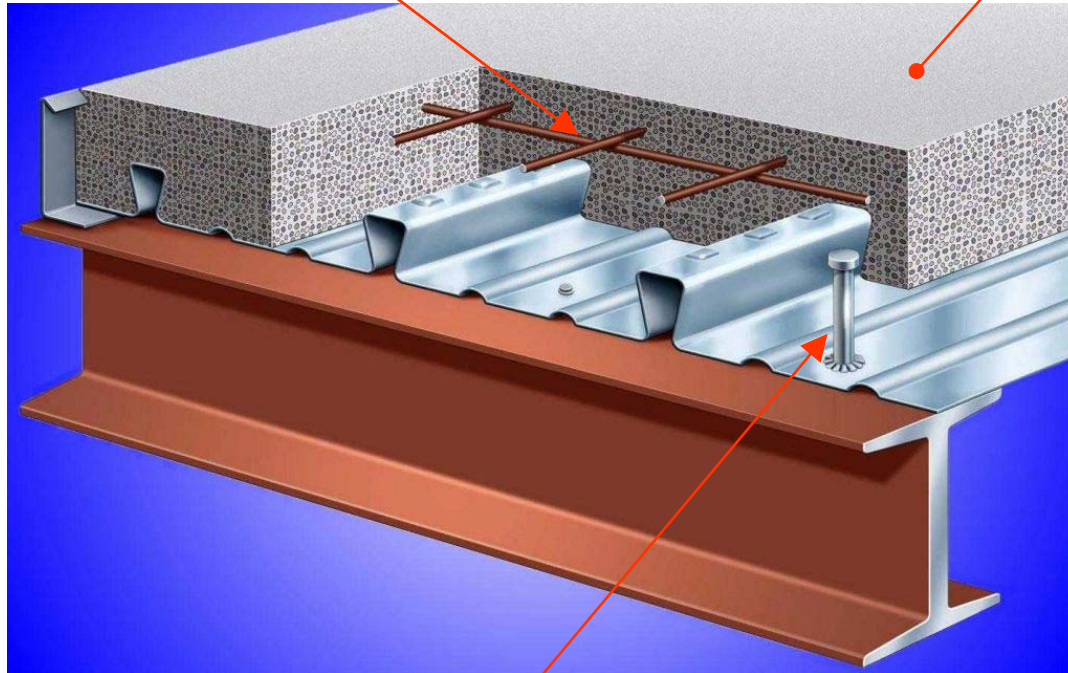

Headed stud connectors for shear connection to the composite beam and, when required, end anchorage to the slab







- **Bending resistance increased by a factor of 1.5 to 2.5**
- **Stiffness increased by a factor of 3 to 4.5**
- **Steel weight reduced by typically 30 to 50%**
- **Reduction in beam depth (span:depth \approx 25)**
- **Lightweight construction**



- **Profiled steel sheeting acts as a safe working platform and permanent formwork.**
- **Unpropped construction may be achieved.**
- **Sheeting can stabilise beams during construction.**
- **Sheeting can provide all, or part, of the main tension reinforcement to the slab.**



Commercial sector



Residential sector

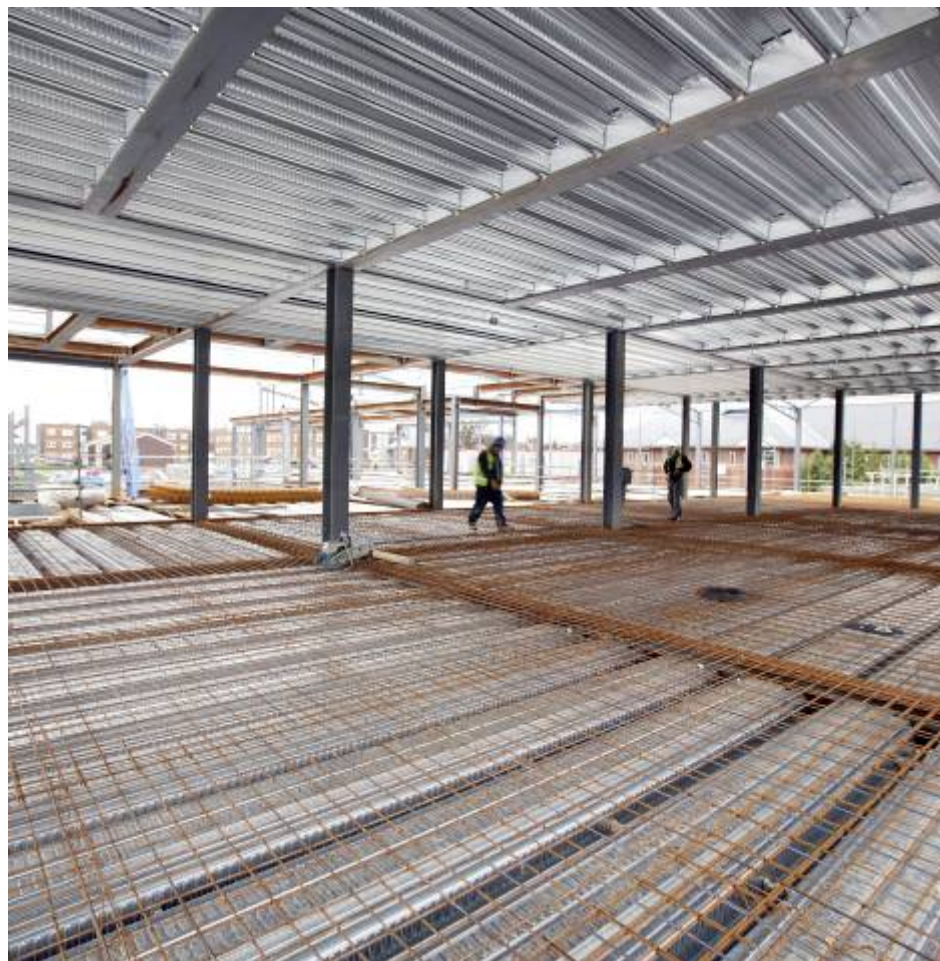

Health sector

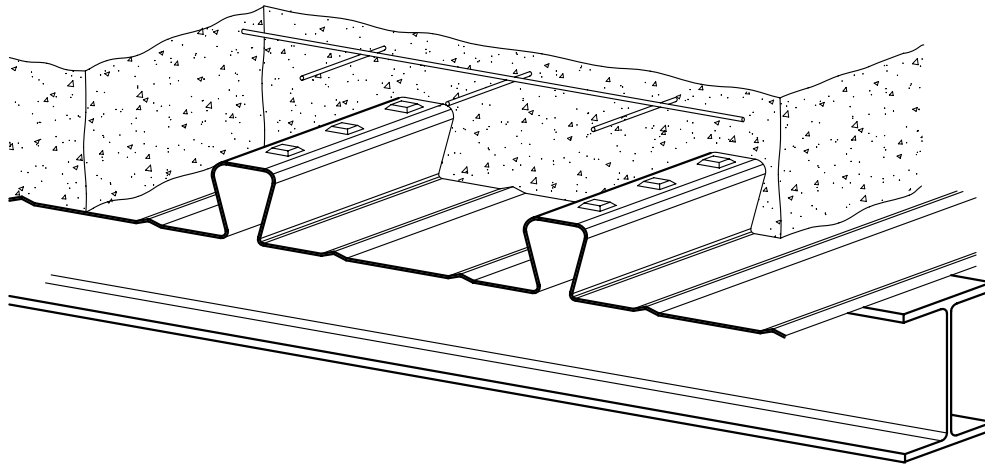

Re-entrant profiled steel sheet

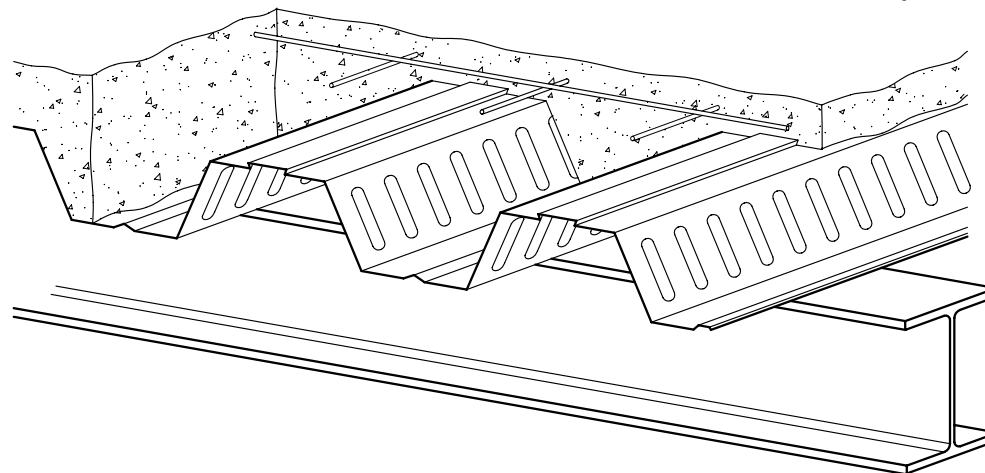

Open trough profiled steel sheet

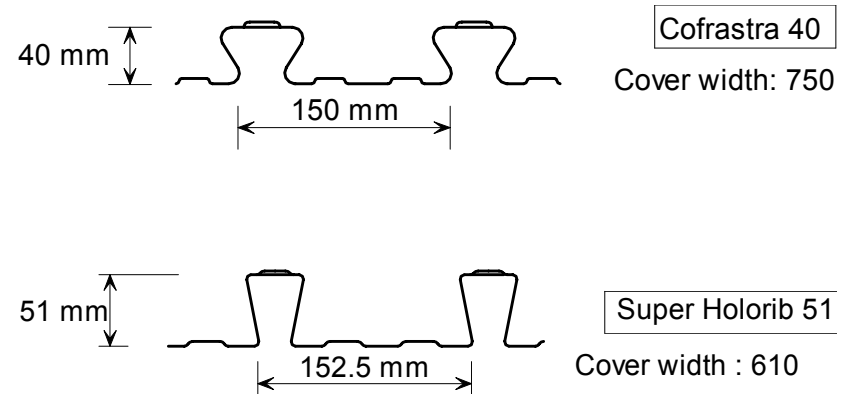
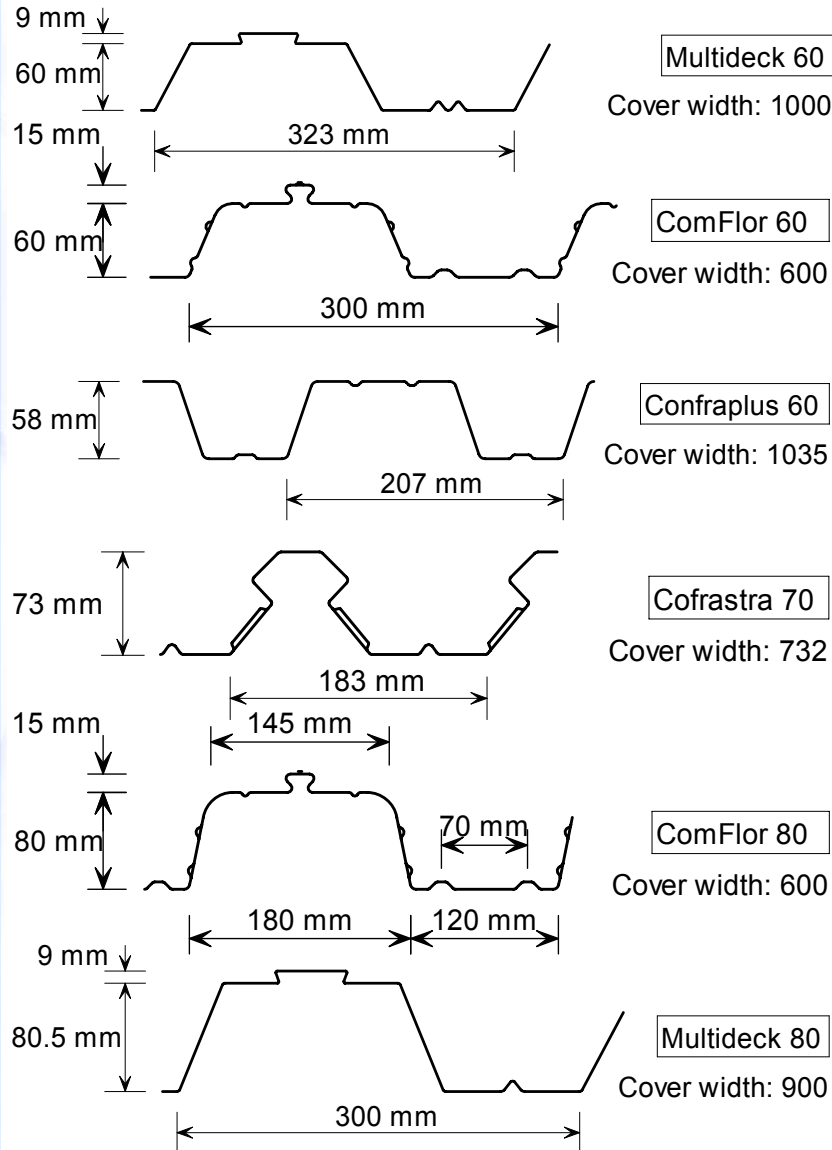





Wedge attachment



Clip attachment

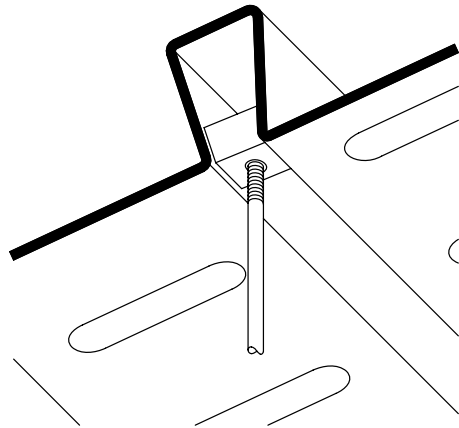

Alternative wedge attachment

Re-entrant trough profile

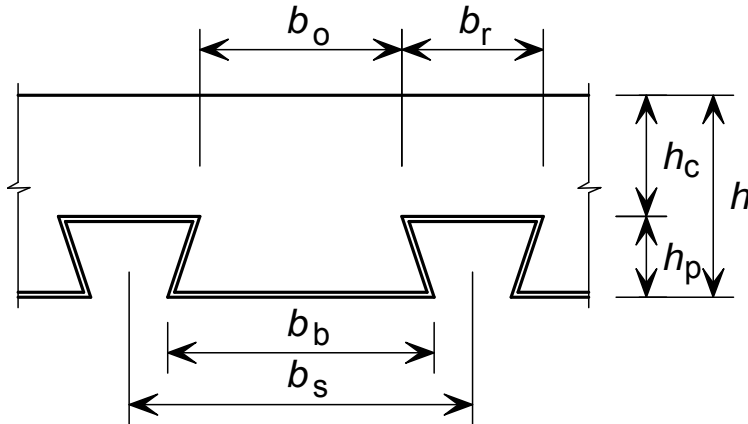

Scope limited to sheets with narrowly spaced ribs : $b_r / b_s \leq 0,6$

Slab thickness

When slab is acting compositely with beam or is used as a diaphragm:
 $h \geq 90 \text{ mm}$ & $h_c \geq 90 \text{ mm}$

When slab is not acting compositely with beam or has no stabilizing function:
 $h \geq 80 \text{ mm}$ & $h_c \geq 40 \text{ mm}$

Open trough profile

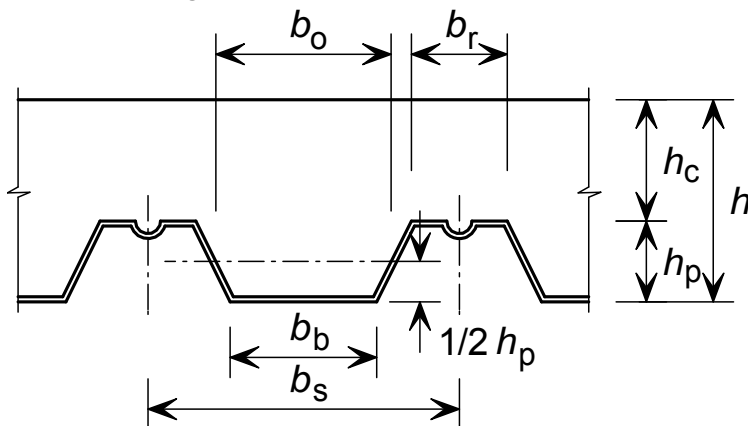

Reinforcement $\geq 80 \text{ mm}^2/\text{m}$ in both directions

Spacing of reinforcement bars
 $s \leq 2h$ & 350 mm

Maximum aggregate size
 $d_g \leq 0,4 h_c$, $b_o / 3$ and $31,5 \text{ mm}$

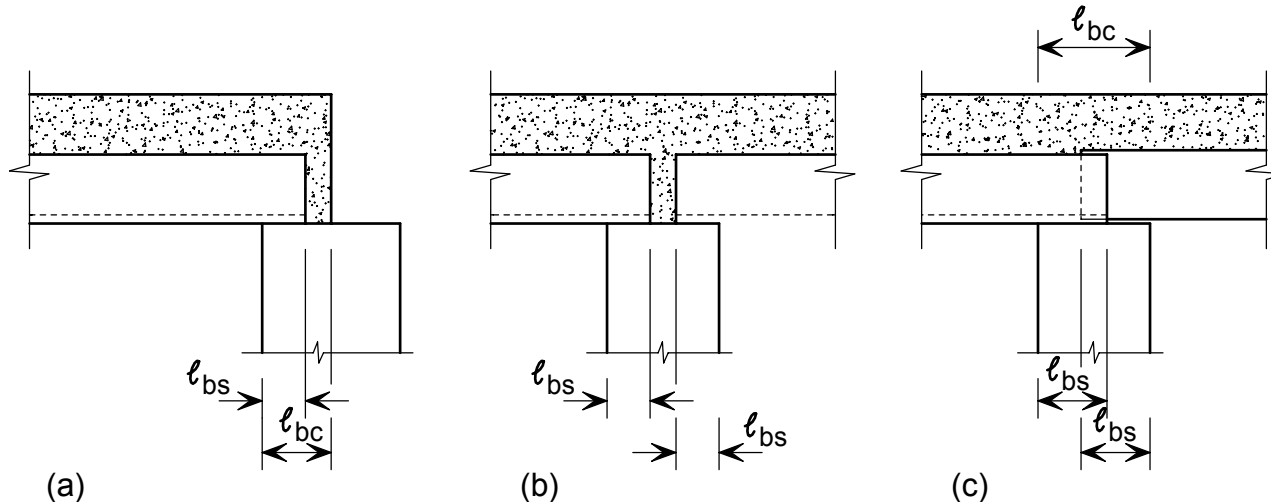

The bearing length shall be such that damage to the slab and the bearing is avoided; that fastening of the sheet to the bearing can be achieved without damage to the bearing and that collapse cannot occur as a result of accidental displacement during erection.

- For bearing on steel or concrete: $l_{bc} = 75 \text{ mm}$ and $l_{bs} = 50 \text{ mm}$
- For bearing on other materials: $l_{bc} = 100 \text{ mm}$ and $l_{bs} = 70 \text{ mm}$

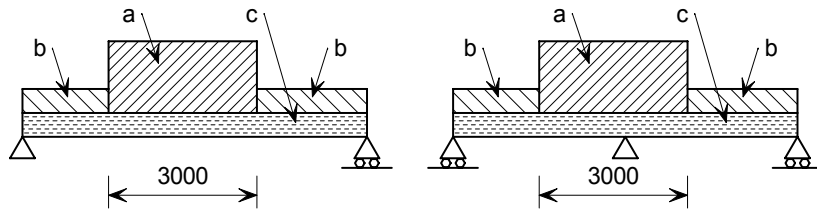

a) Imposed load on a 3 m × 3 m working area (or the length of the span if less), with an intensity of 10% of the self-weight of the concrete but $\leq 1,5 \text{ kN/m}^2$ and $\geq 0,75 \text{ kN/m}$

b) Imposed load of $0,75 \text{ kN/m}^2$

c) Self weight load corresponding to the design thickness of the slab plus ponding effects if $\delta > h / 10$



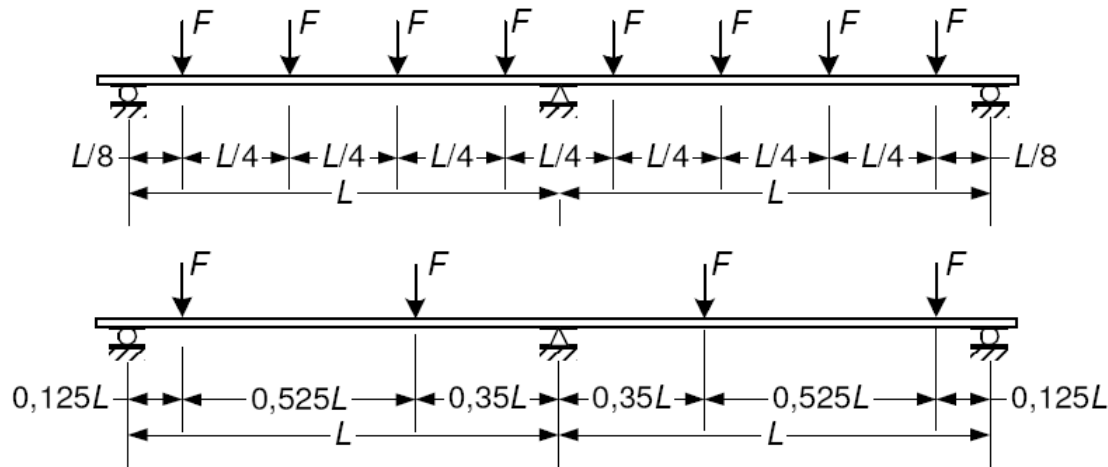

Combined bending and crushing at internal support



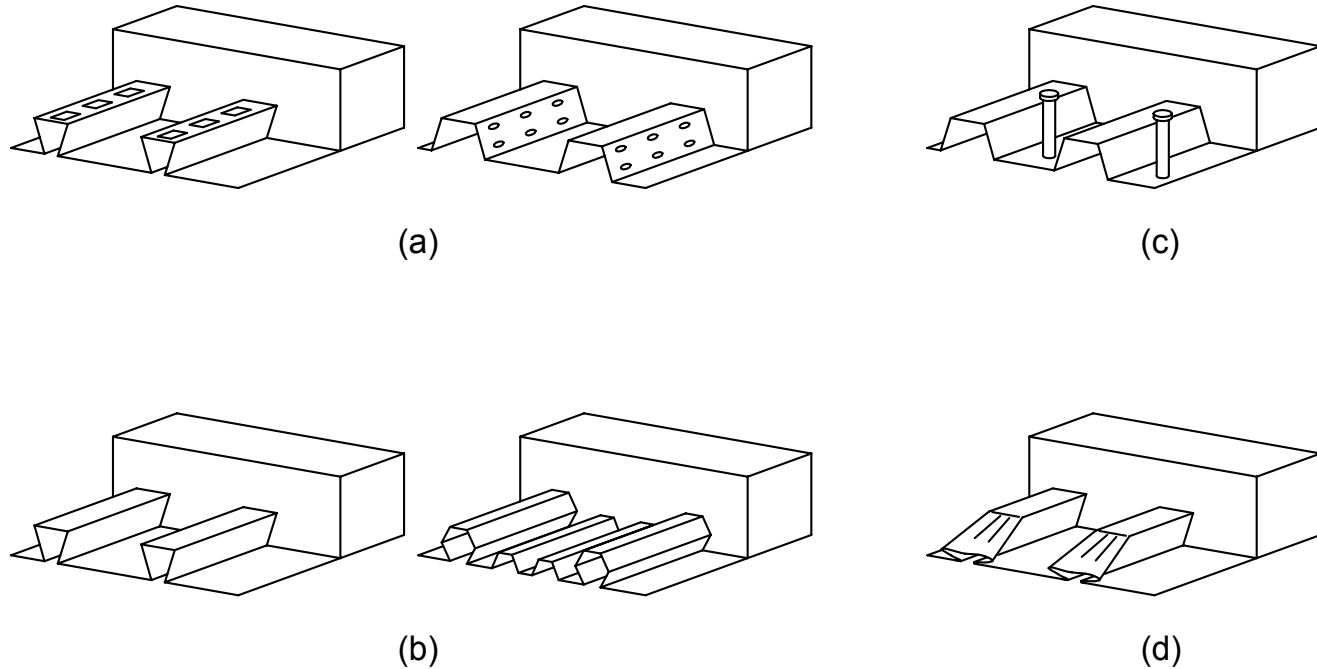

- a) Mechanical interlock through the provision of indentations or embossments rolled into the profile.**
- b) Frictional interlock for re-entrant profiles.**
- c) End anchorage from through-deck welded stud connectors or other local connection.**
- d) End anchorage from deformation of the ends of the ribs at the end of the sheeting.**

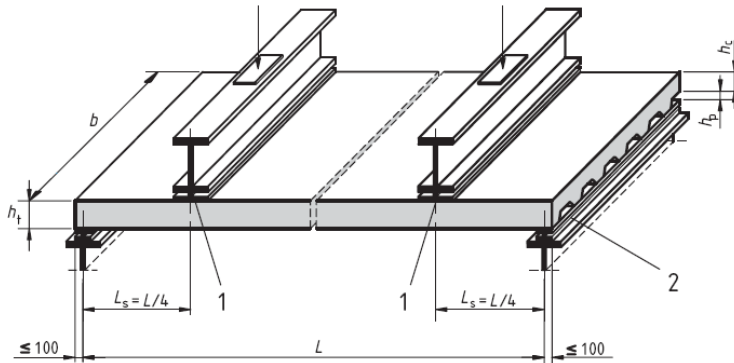

Key

- 1 neoprene pad or equivalent $\leq 100 \text{ mm} \times b$
- 2 support bearing plate $\leq 100 \text{ mm} \times b \times 10 \text{ mm (min)}$ (typical for all bearing plates)



Test set-up from EN 1994-1-1, Annex B

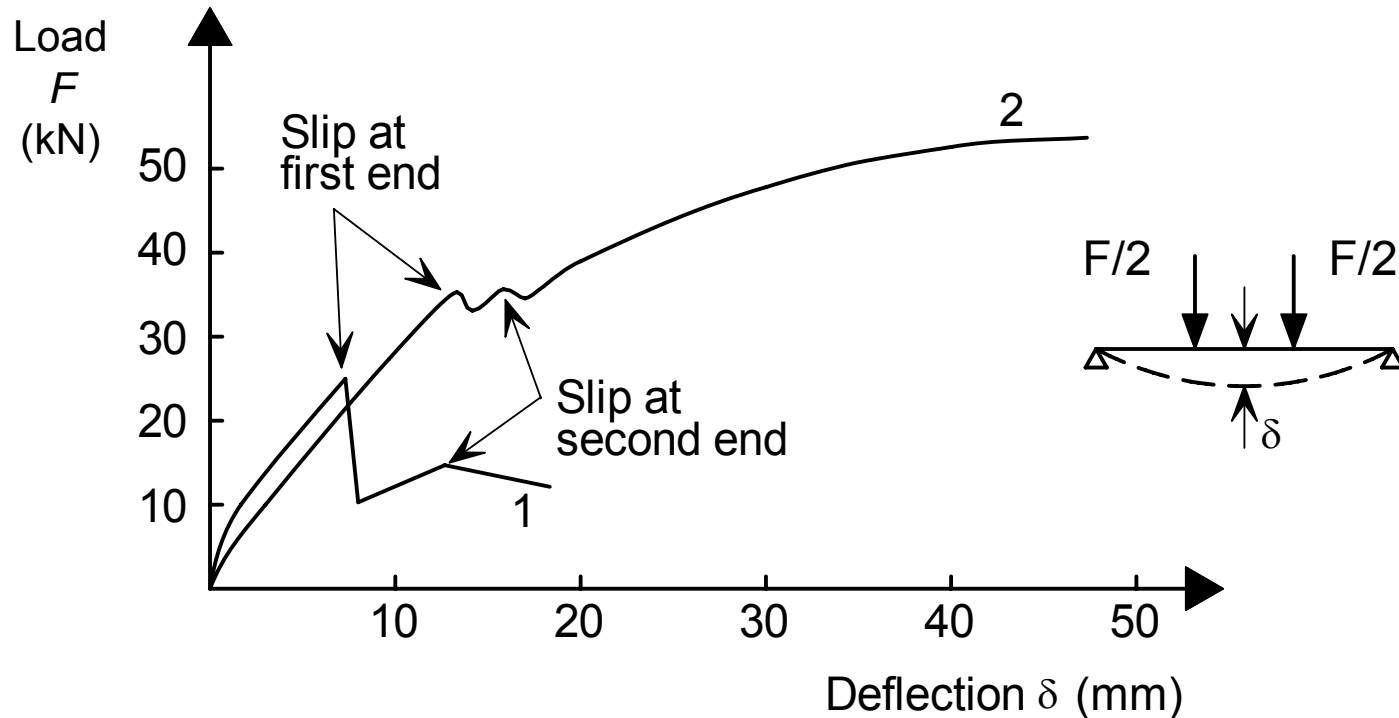

1. Brittle behaviour

- o *m-k* method

2. Ductile behaviour - failure load exceeds the load causing a recorded end slip of 0,1 mm by more than 10%

- o Partial connection method
- o *m-k* method

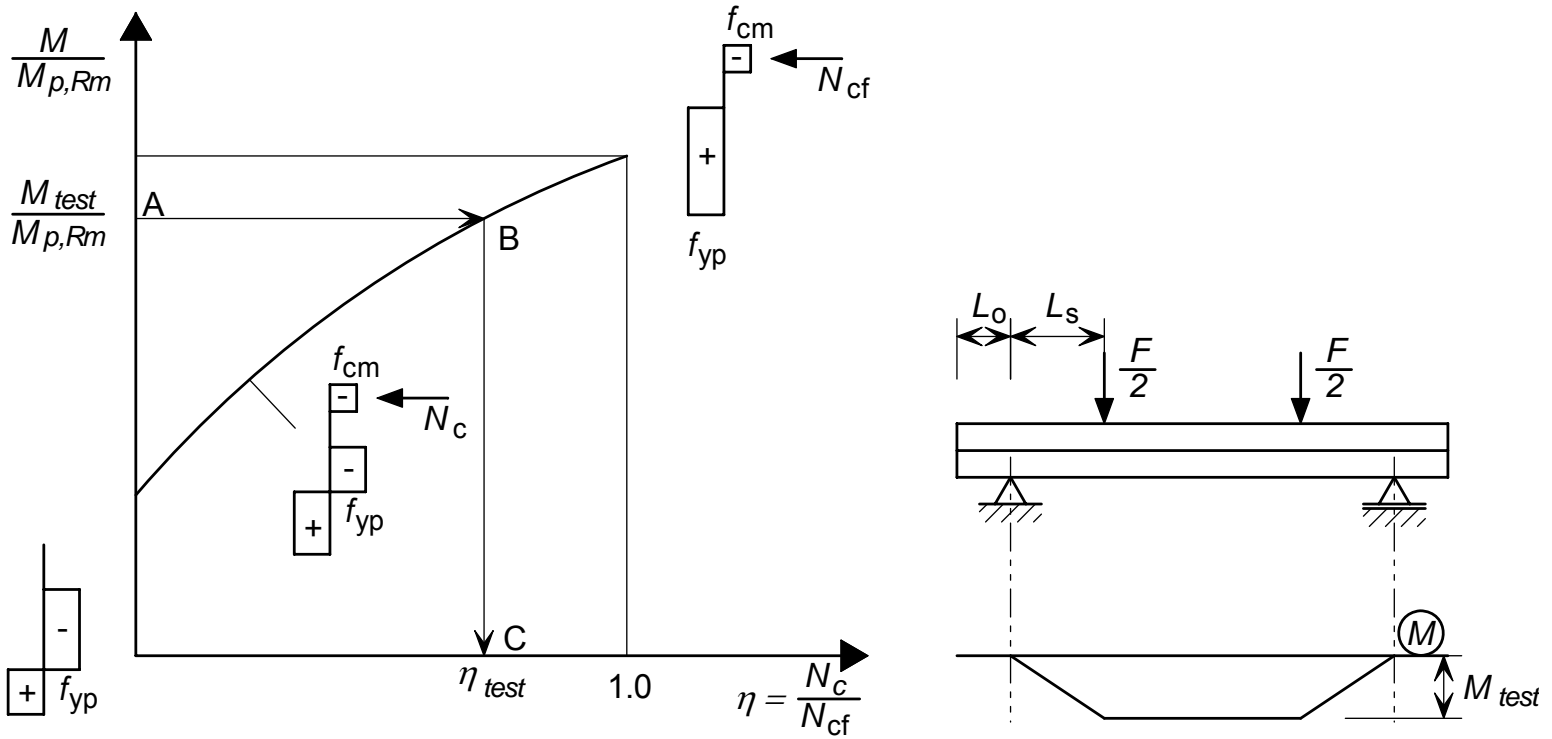

Mean value for the ultimate shear stress:

$$\tau_u = \frac{\eta_{test} N_{cf}}{b(L_s + L_o)}$$

Mean value for the ultimate shear stress with additional longitudinal shear resistance caused by the support reaction:

$$\tau_u = \frac{\eta_{test} N_{cf} - \mu V_t}{b(L_s + L_o)}$$

For each variable investigated:

- 3 test specimens with the shear span L_s as long as possible, whilst still providing failure in longitudinal shear.
- 1 test specimen with the shear span L_s as short as possible (but not less than $3 \times$ overall slab thickness), whilst still providing failure in longitudinal shear to classify the behaviour

Characteristic value of the longitudinal shear strength $\tau_{u,Rk}$ calculated from the test values as the 5% fractile from EN1990, Annex D

$\tau_{u,Rk}$ is divided by the partial safety factor γ_{Vs} to obtain a design value $\tau_{u,Rd}$

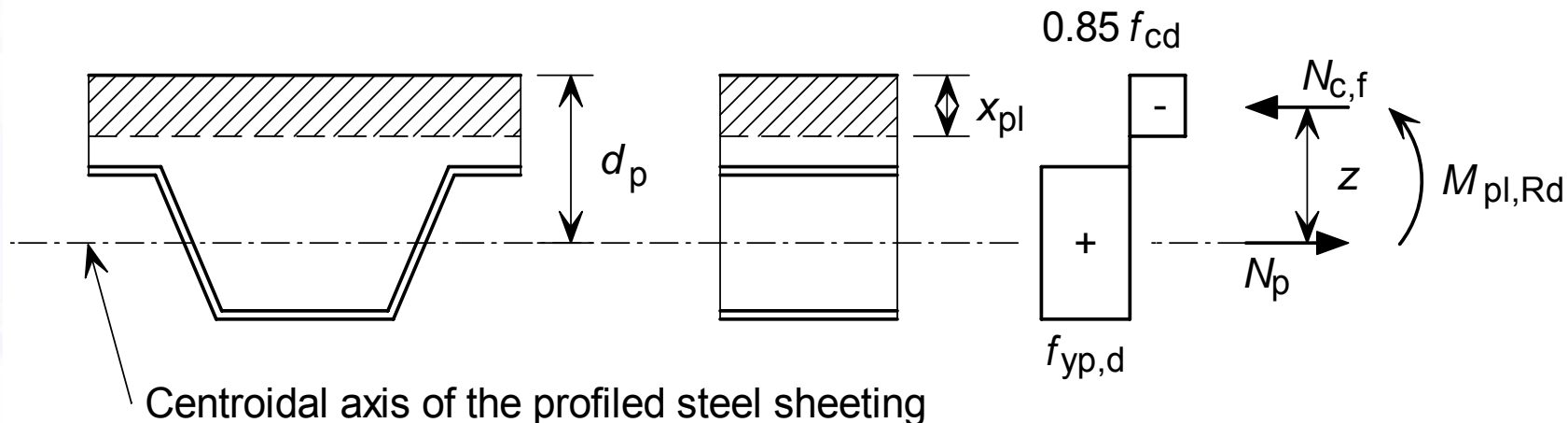

Design compressive normal force in the concrete flange:

$$N_{c,f} = N_p = A_{pe} f_{yp,d}$$

Depth of the concrete in compression

$$x_{pl} = N_{c,f} / (0,85 f_{cd} b) \leq h_c$$

Design moment resistance of the composite slab in sagging bending

$$M_{Rd} = N_{c,f} (d_p - 0,5 x_{pl})$$

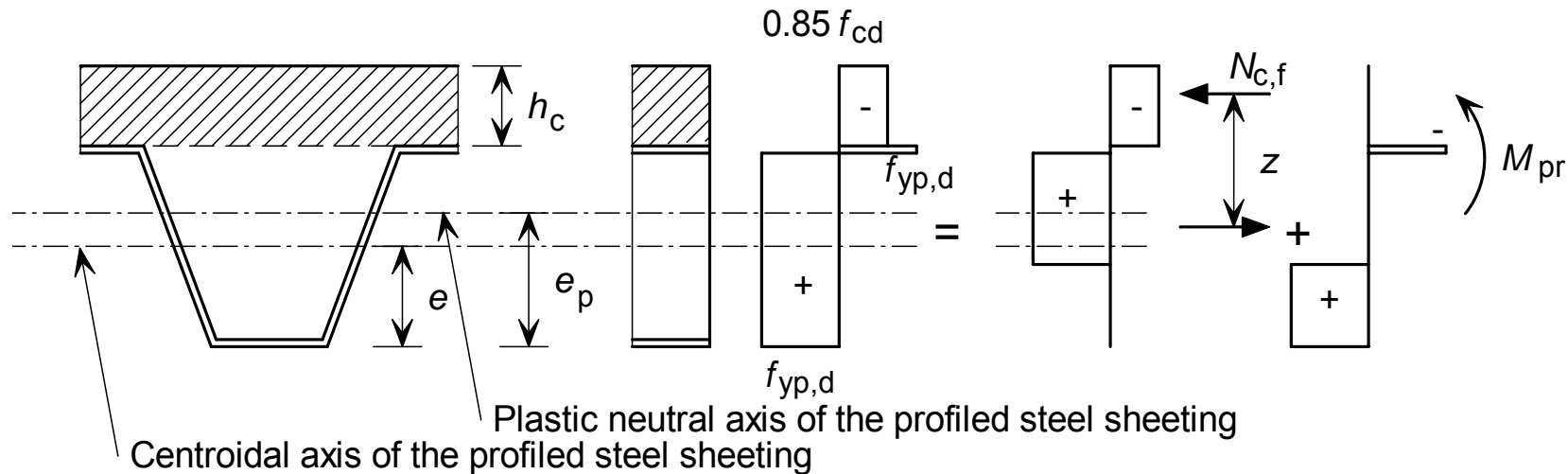

Design compressive normal force in the concrete flange: $N_{c,f} = 0,85 f_{cd} b h_c$

Reduced plastic moment resistance of the sheeting: $M_{pr} = 1,25M_{pa} \left(1 - \frac{N_{cf}}{A_{pe} f_{yp,d}} \right)$

Lever arm: $z = h - 0,5h_c - e_p + (e_p - e) \frac{N_{cf}}{A_{pe} f_{yp,d}}$

Design moment resistance of the composite slab in sagging bending

$$M_{Rd} = N_{c,f} z + M_{pr}$$

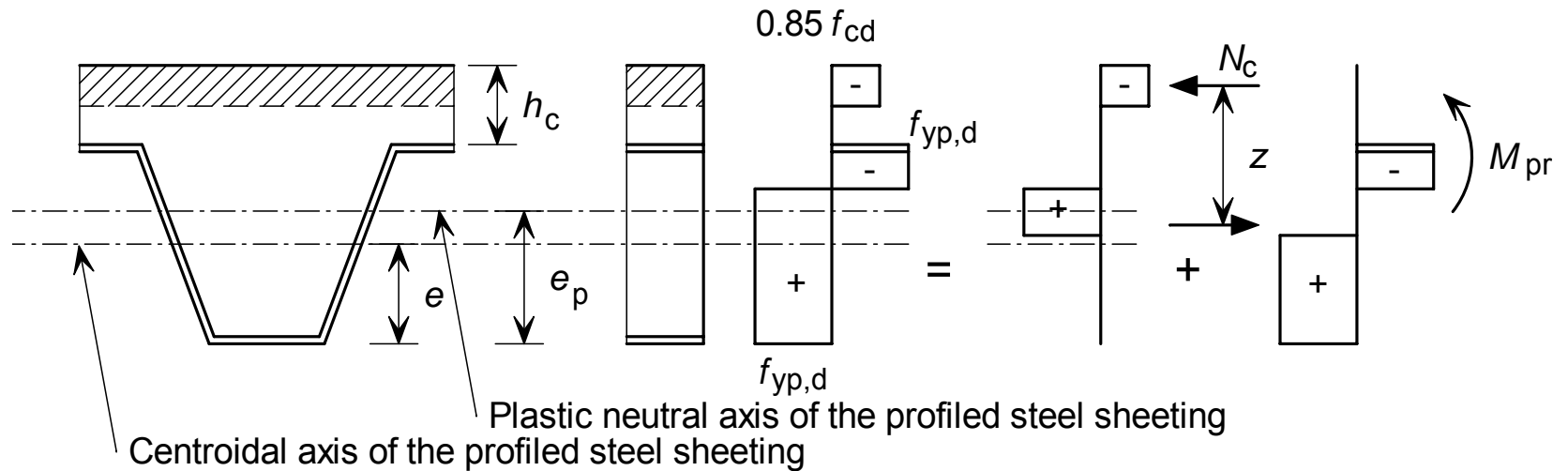

Design compressive normal force in the concrete flange: $N_c = \tau_{u,Rd} b L_x \leq N_{c,f}$

Reduced plastic moment resistance of the sheeting: $M_{pr} = 1,25M_{pa} \left(1 - \frac{N_c}{A_{pe} f_{yp,d}} \right)$

Lever arm: $z = h - 0,5h_c - e_p + (e_p - e) \frac{N_c}{A_{pe} f_{yp,d}}$

Design moment resistance of the composite slab in sagging bending

$$M_{Rd} = N_c z + M_{pr}$$

According to EN 1994-1-1, design resistance of a headed stud welded through the steel sheet used for end anchorage should be taken as the lesser of:

$$P_{Rd} k_t$$

or

$$P_{pb,Rd} = k_\varphi d_{d0} t f_{yp,d}$$

where P_{Rd} is the design resistance of a headed stud embedded in concrete, k_t is a reduction factor for deck shape, d_{d0} is the diameter of the weld collar (which may be taken as 1,1 times the shank diameter), t is the sheet thickness and $k_\varphi = 1 + a / d_{d0} \leq 6,0$

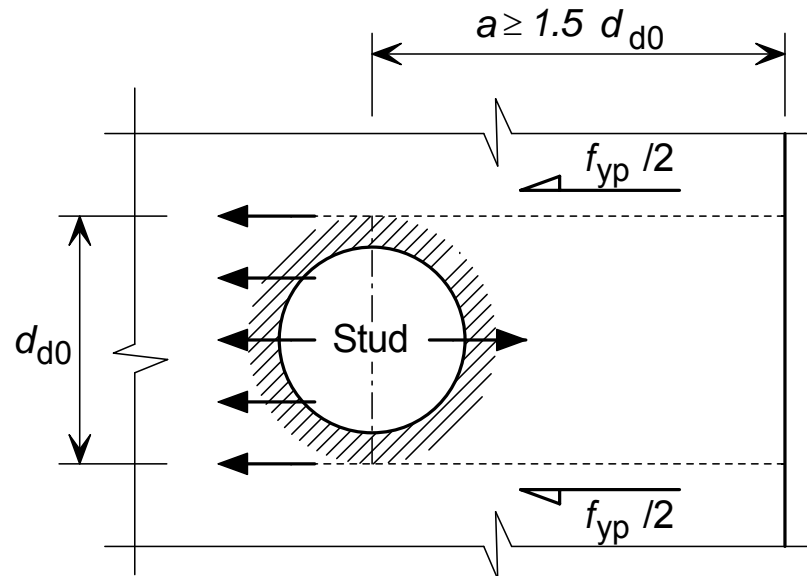

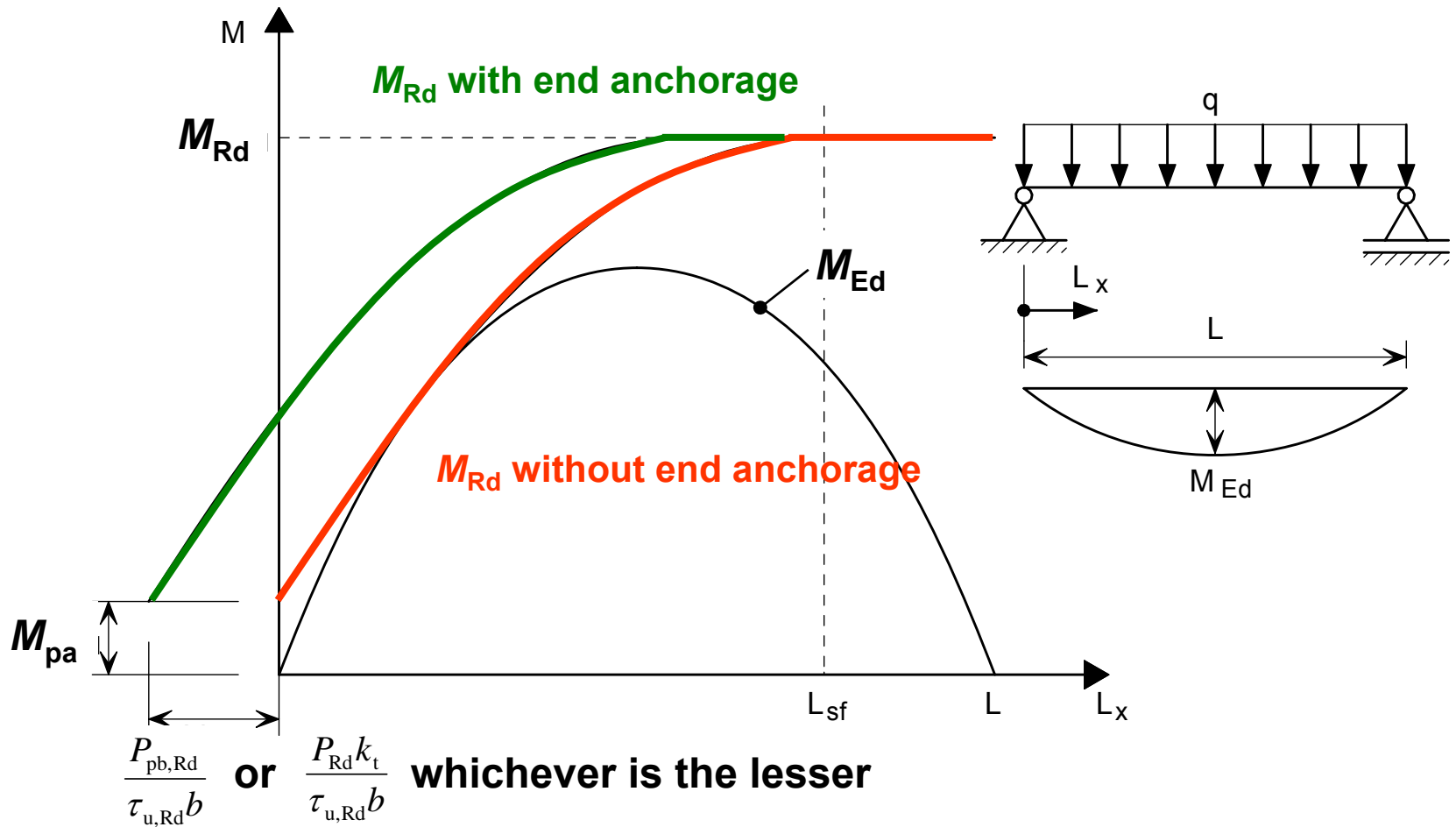

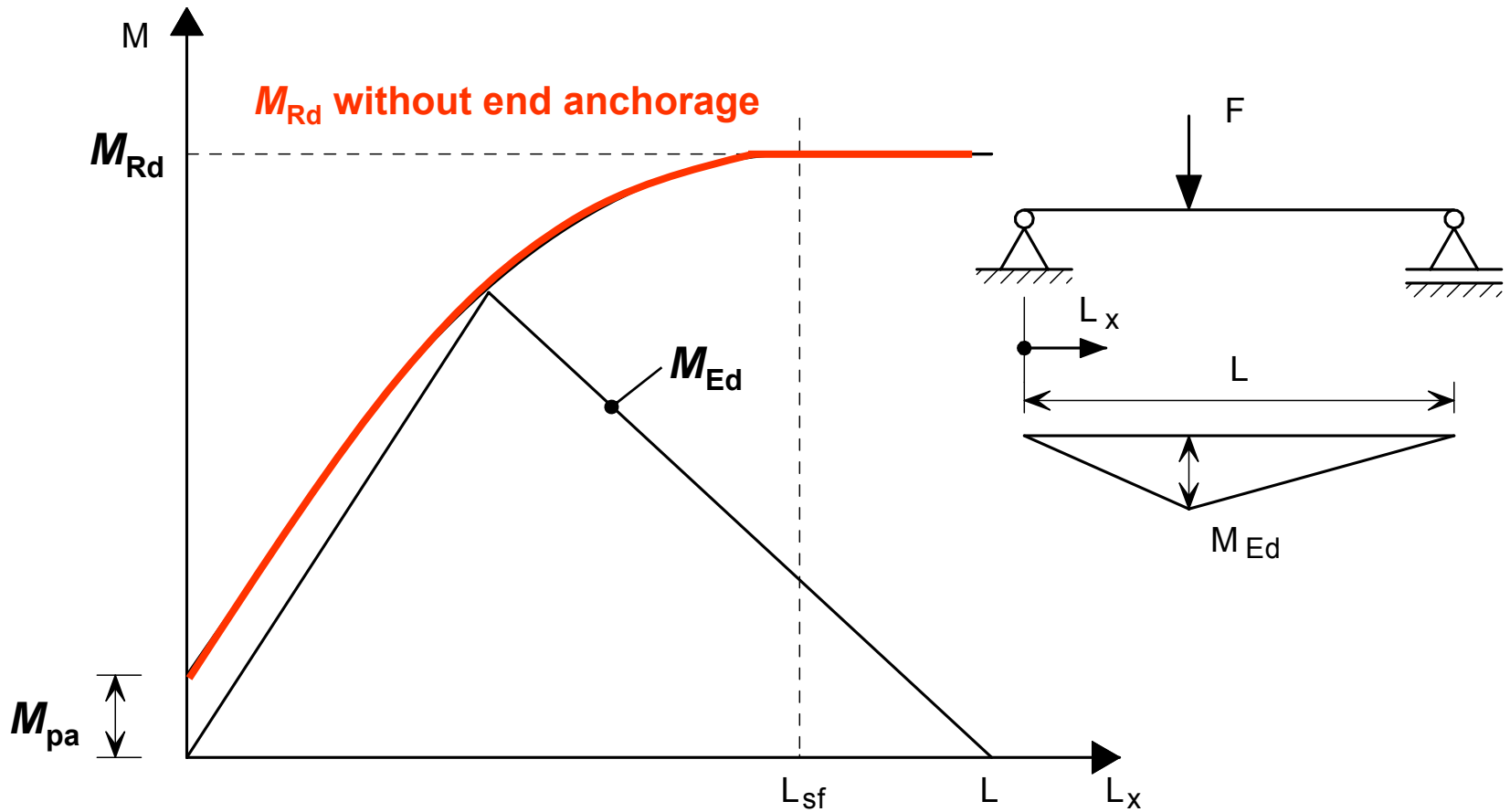

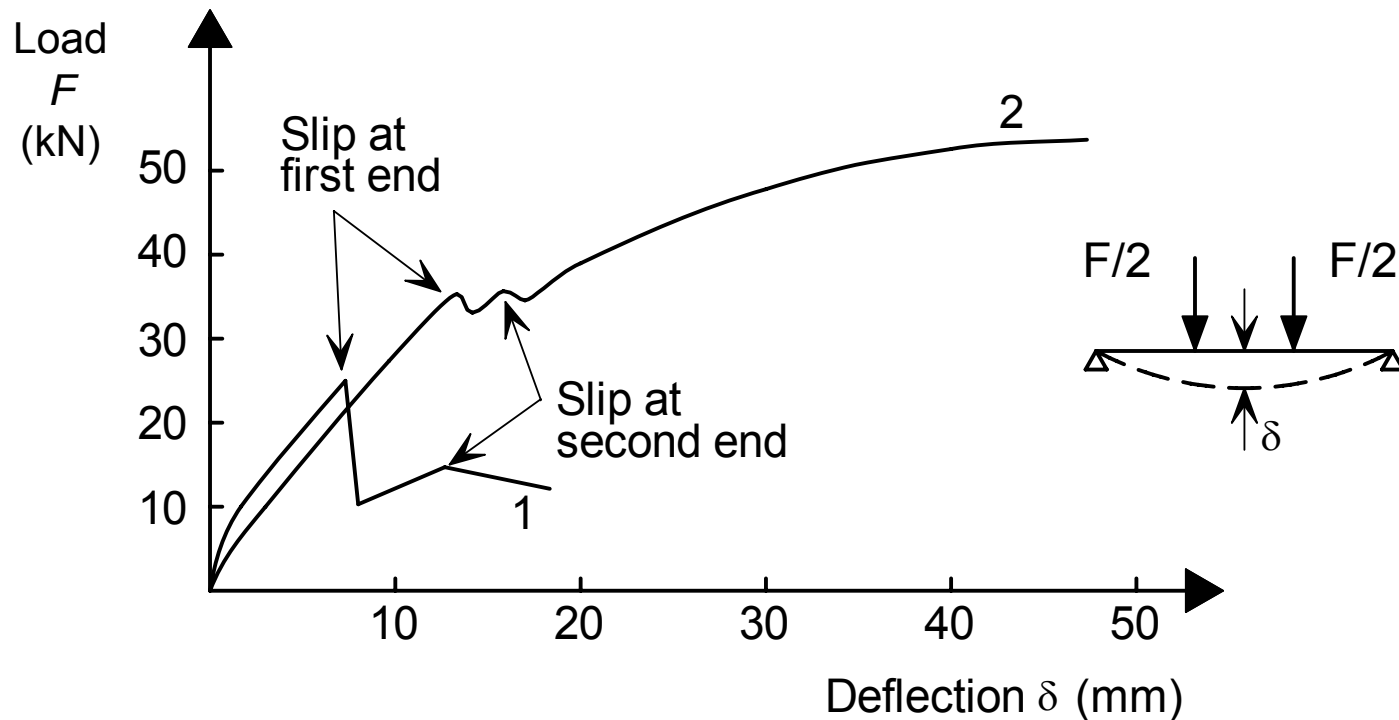

1. Brittle behaviour

- o *m-k* method

2. Ductile behaviour - failure load exceeds the load causing a recorded end slip of 0,1 mm by more than 10%

- o Partial connection method
- o *m-k* method

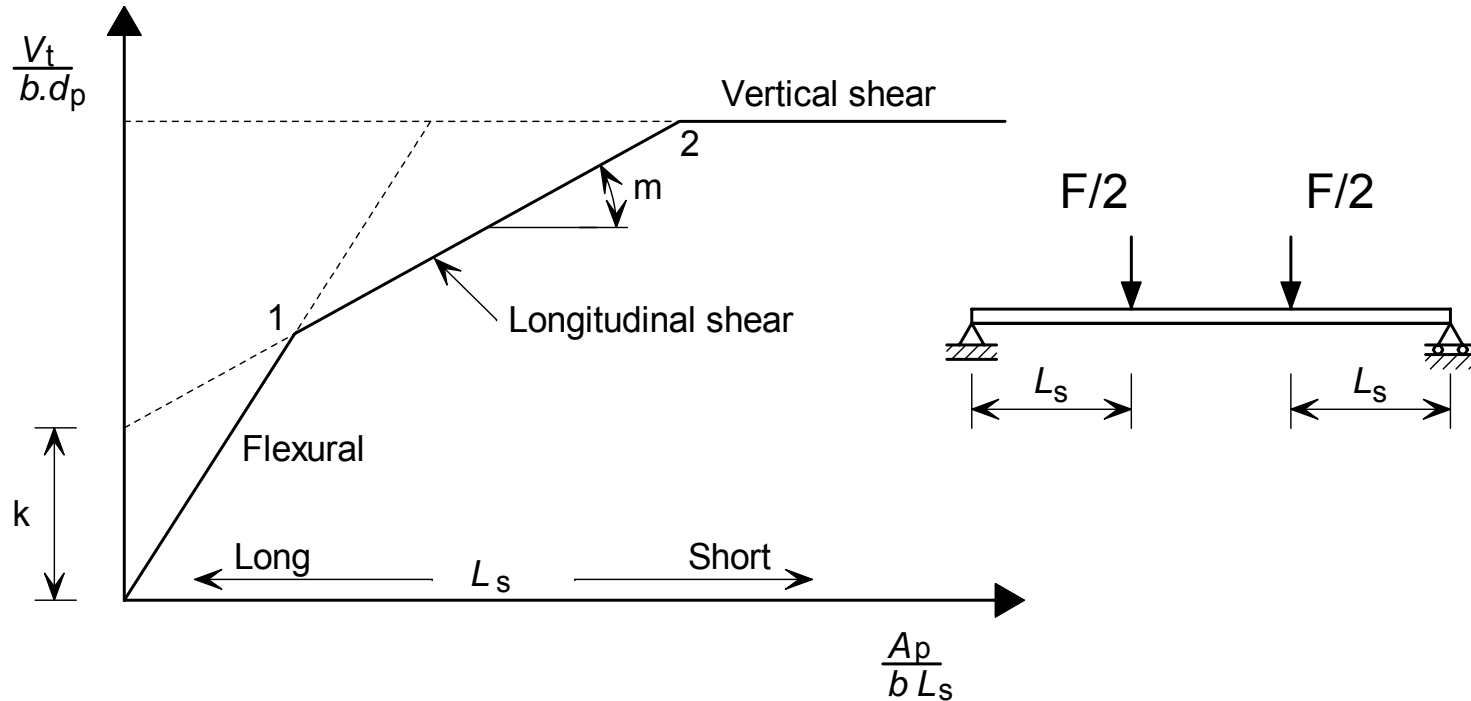

For each variable investigated:

- 3 test specimens with the shear span L_s as long as possible, whilst still providing failure in longitudinal shear.
- 3 test specimens with the shear span L_s as short as possible (but not less than $3 \times$ overall slab thickness), whilst still providing failure in longitudinal shear to classify the behaviour

If behaviour brittle, $V_t = 0,8 (F / 2)$

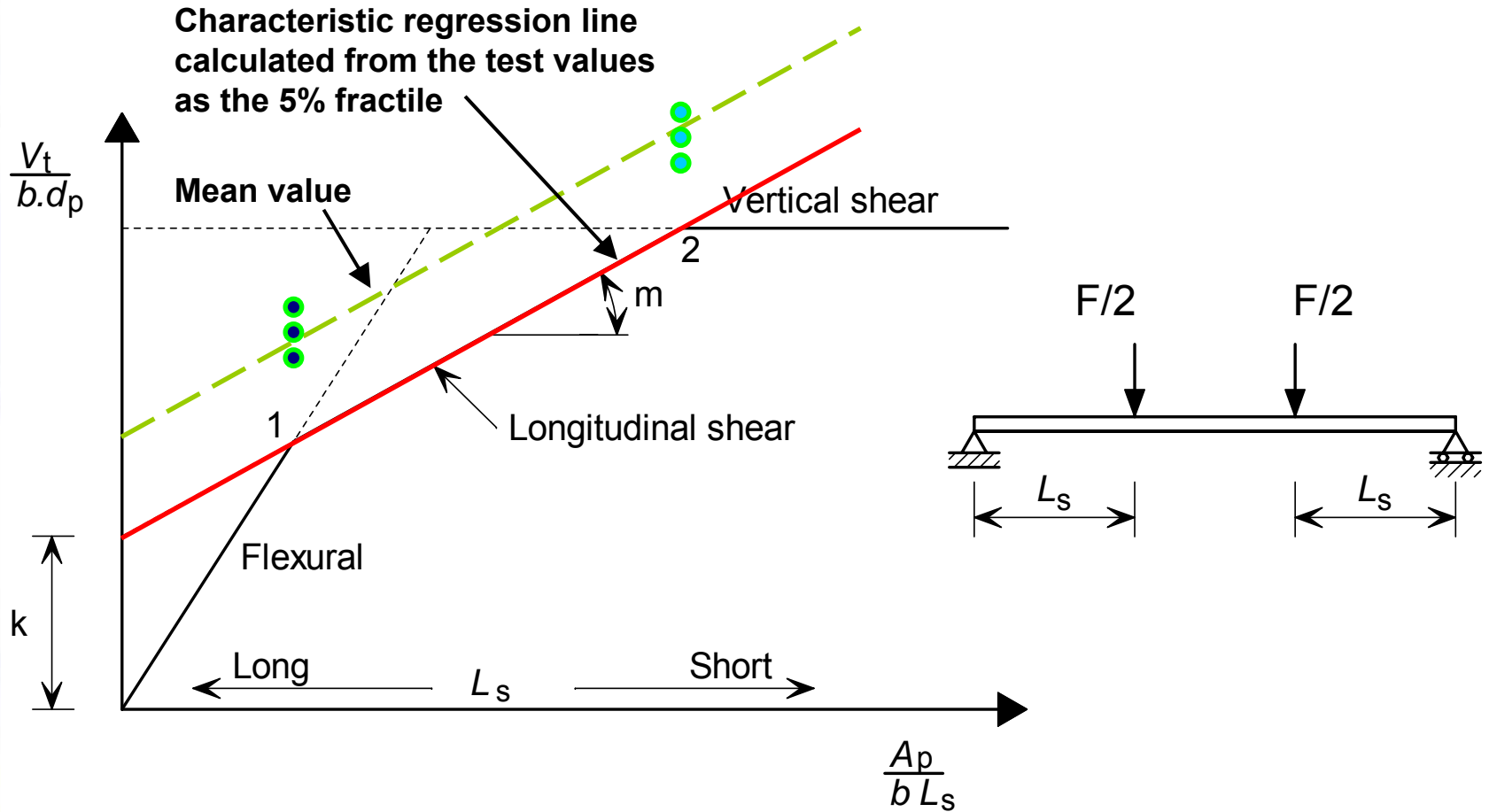

Design shear resistance

$$V_{l,Rd} = \frac{b d_p}{\gamma_{VS}} \left(\frac{m A_p}{b L_s} + k \right)$$



- **The results contain all the influencing parameters, but are impossible to separate from one another.**
- **Methodology is not based on a mechanical model and is therefore less flexible than the partial connection approach (contribution from end anchorage and reinforcement need to be evaluated from additional tests).**
- **Other loading arrangements that differ from the test loading can be problematical.**

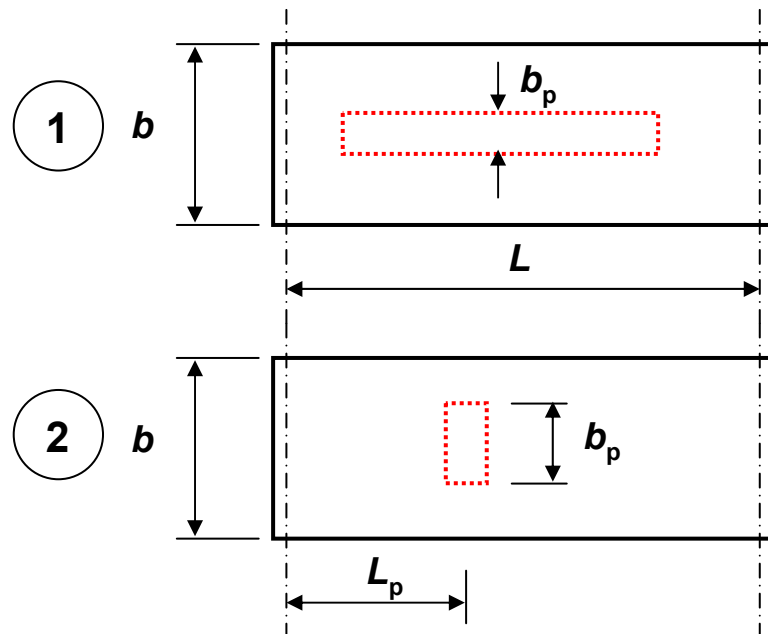
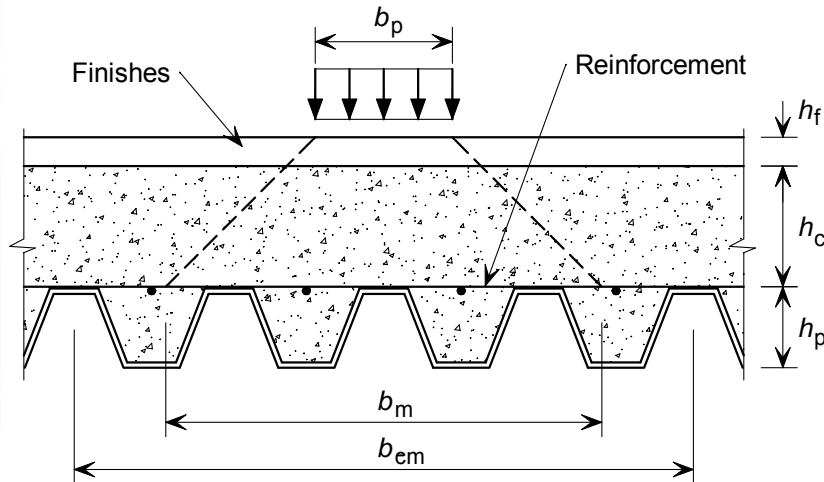

For $h_p / h \leq 0,6$

For bending and longitudinal shear:
i) for simple spans and exterior spans of continuous slabs

$$b_{em} = b_m + 2L_p \left(1 - \frac{L_p}{L} \right) \leq b$$

ii) for interior spans of continuous slabs

$$b_{em} = b_m + 1,33L_p \left(1 - \frac{L_p}{L} \right) \leq b$$

For vertical shear

$$b_{ev} = b_m + L_p \left(1 - \frac{L_p}{L} \right) \leq b$$

Width of slab over which load is distributed

$$b_m = b_p + 2 (h_c + h_f)$$

Case ① – Concentrated loads applied parallel to the span

Case ② – Concentrated loads applied perpendicular to the span

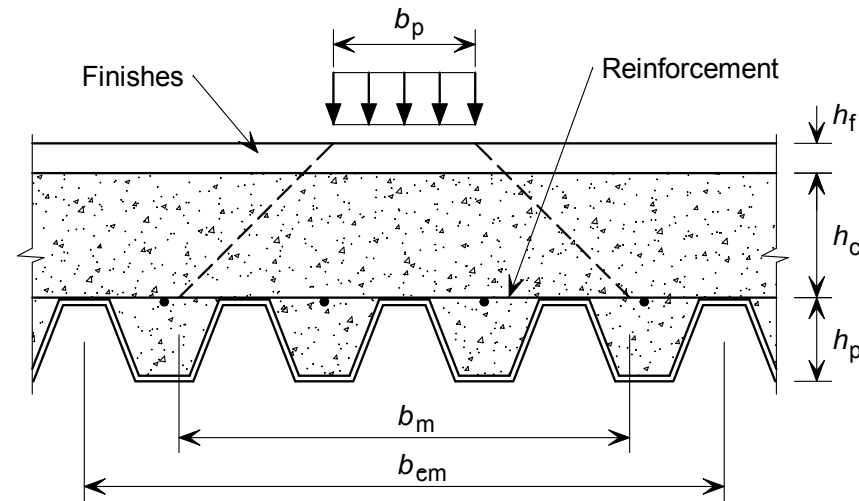

If the characteristic imposed loads do not exceed the values given below, a nominal transverse reinforcement of not less than 0,2% of the area of concrete above the ribs of the sheet (which extends \geq the minimum anchorage length beyond b_{em}), may be provided without any further calculation:

- concentrated load: 7,5 kN;
- distributed load: 5,0 kN/m².

For characteristic imposed loads greater than these values, the distribution of bending moments and the appropriate amount of transverse reinforcement should be evaluated according to EN 1992-1-1.



$V_{v,Rd}$ should be determined using EN 1992-1-1, 6.2.2 which gives the following:

$$V_{v,Rd} = [C_{Rd,c} k(100\rho_1 f_{ck})^{1/3} + k_1 \sigma_{cp}] b_s d \quad (6.2a)$$

with a minimum of

$$V_{v,Rd} = (v_{min} + k_1 \sigma_{cp}) b_s d \quad (6.2b)$$

where $\rho_1 = A_{sl} / b_s d$, A_{sl} is the area of the tensile reinforcement which extends $\geq (l_{bd} + d)$ beyond the section considered and other symbols are defined in EN1992-1-1.

For normal loading conditions, and the fact that the sheeting is unlikely to be fully anchored, the vertical shear resistance will commonly be based on Eq (6.2b).

For heavily loaded slabs, additional reinforcement bars may be required at the support and the vertical shear resistance based on Eq (6.2a). According to the ENV version of EN 1994-1-1, it is permitted to assume that the sheeting contributes to A_{sl} provided that it is fully anchored beyond the section considered.

The punching shear resistance $V_{p,Rd}$ should be calculated according to EN 1992-1-1. For a loaded area $a_p \times b_p$, which is applied to a screed with a thickness h_f , the critical perimeter is given by:

$$c_p = 2\pi h_c + 2(b_p + 2h_f) + 2(a_p + 2h_f + 2d_p - 2h_c)$$

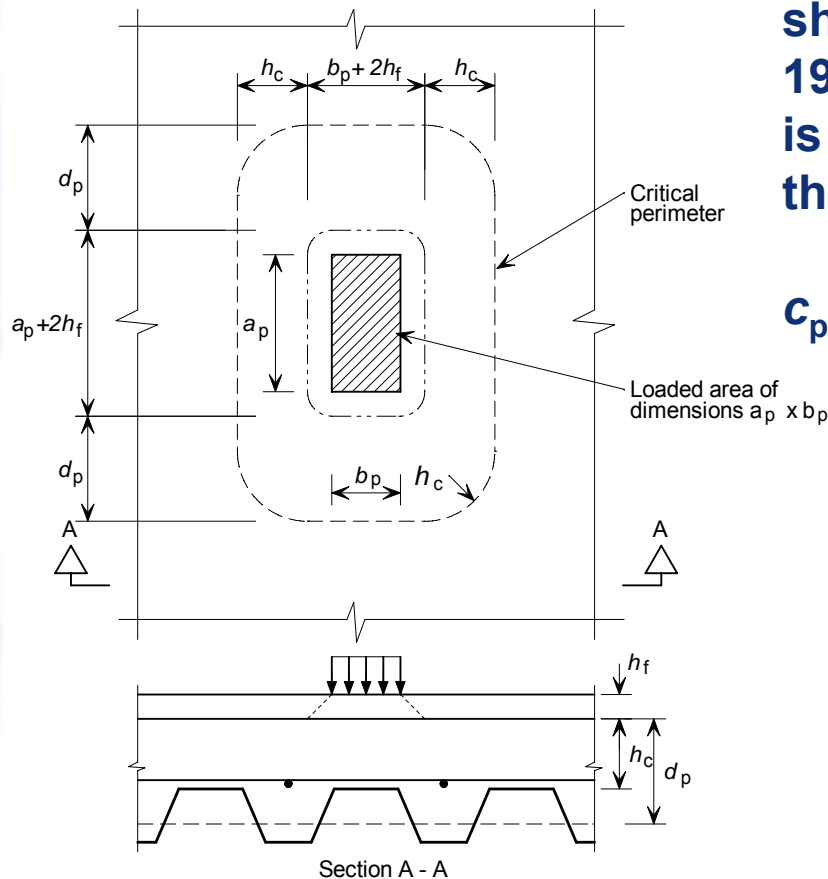



Crack widths

For continuous slabs that are designed as simply-supported, the minimum cross-sectional area of the anti-crack reinforcement within the depth h_c should be:

- 0,2% of the cross-sectional area of the concrete above the ribs for unpropped construction
- 0,4% of the cross-sectional area of the concrete above the ribs for propped construction.

The above amounts do not automatically ensure that $w_{\max} \leq 0,3$ mm as given in EN1992-1-1 for certain exposure classes.

If cracking needs to be controlled, the slab should be designed as continuous, and the crack widths in hogging moment regions evaluated according to EN 1992-1-1, 7.3.

Deflection

Deflections due to loading applied to the composite member should be calculated using elastic analysis, neglecting the effects of shrinkage.

For an internal span of a continuous slab, the deflection may be estimated using the following approximation:

- the average value of the cracked and uncracked second moment of area may be taken.
- for the concrete, an average value of the modular ratio for long-term and short-term effects may be used.

For external, or simply supported spans, calculations of the deflection of the composite slab may be omitted if:

- the span/depth ratio of the slab does not exceed 20 for a simply-supported span and 26 for an external span of a continuous slab (corresponding to the lightly stressed concrete limits given in EN 1992-1-1; **and**
- the load causing an end slip of 0,5 mm in the tests on composite slabs exceeds 1,2 times the design service load.

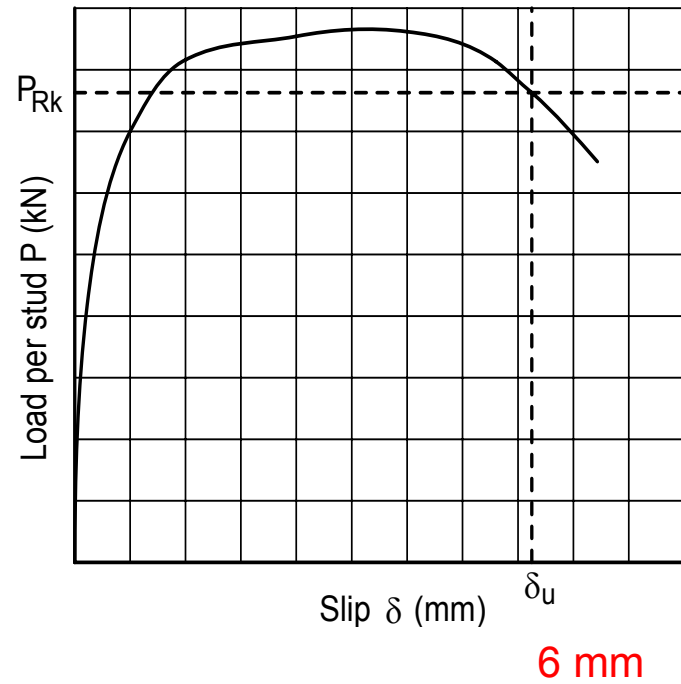
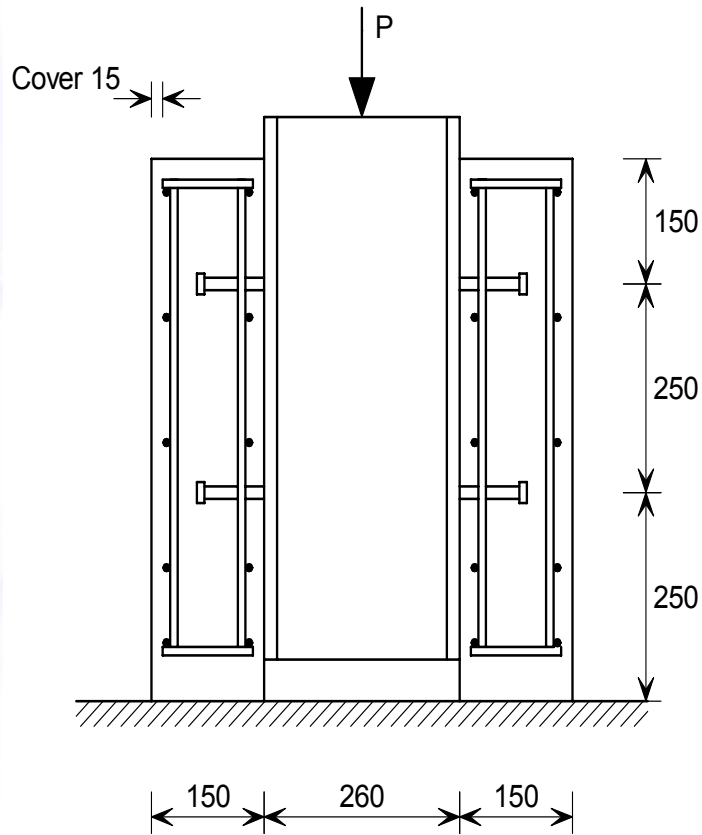

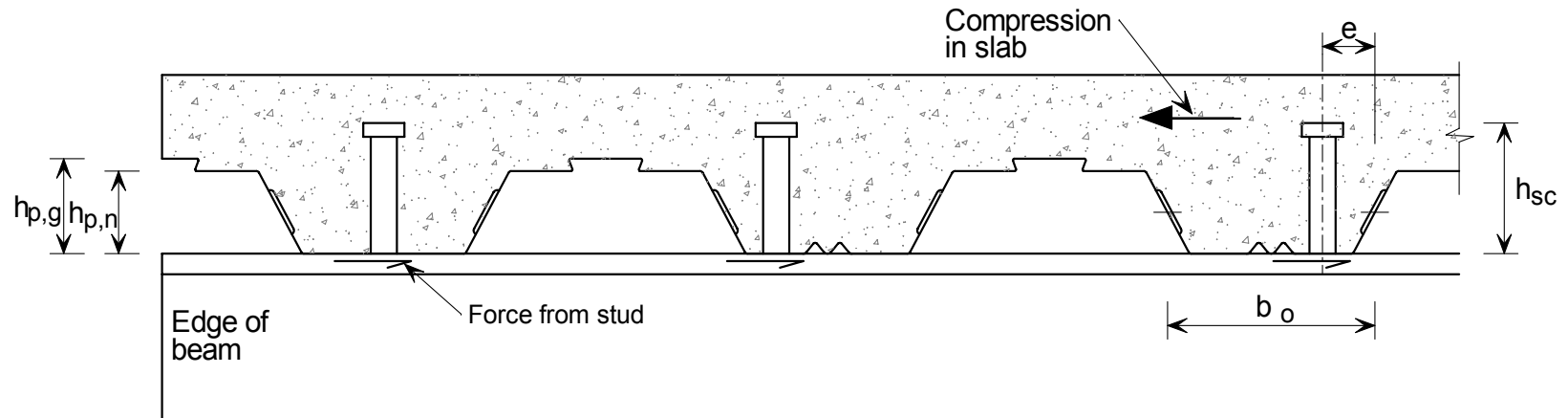

(a) Central

(b) Favourable

(c) Unfavourable

$$k_t = 0.85 / \sqrt{n_r} (b_o / h_p) \{ (h_{sc} / h_p) - 1 \} \leq k_{t,max}$$

Number of stud connectors per rib	Thickness t of sheet (mm)	Studs not exceeding 20 mm in diameter and welded through profiled steel sheeting	Profiled steel sheeting with holes and studs 19 mm or 22 mm in diameter
$n_r = 1$	$\leq 1,0$	0,85	0,75
	$> 1,0$	1,00	0,75
$n_r = 2$	$\leq 1,0$	0,70	0,60
	$> 1,0$	0,80	0,60

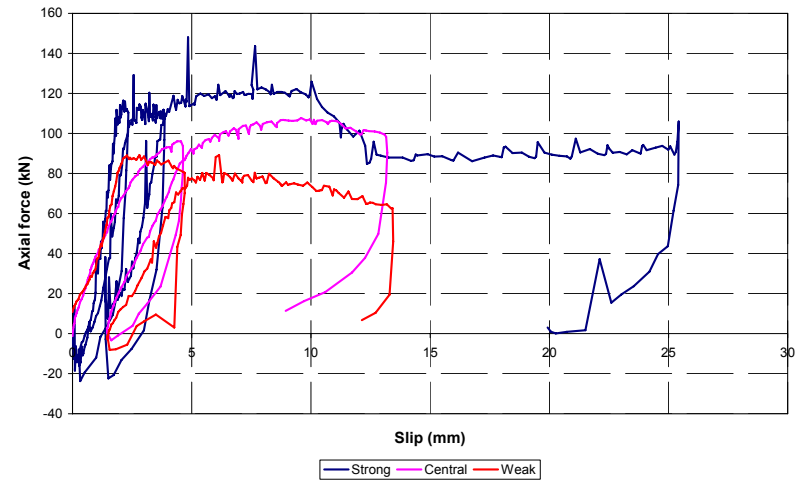
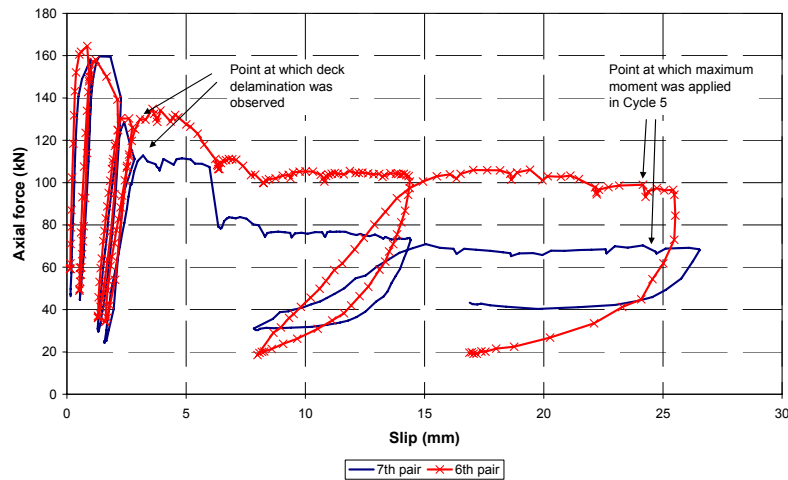

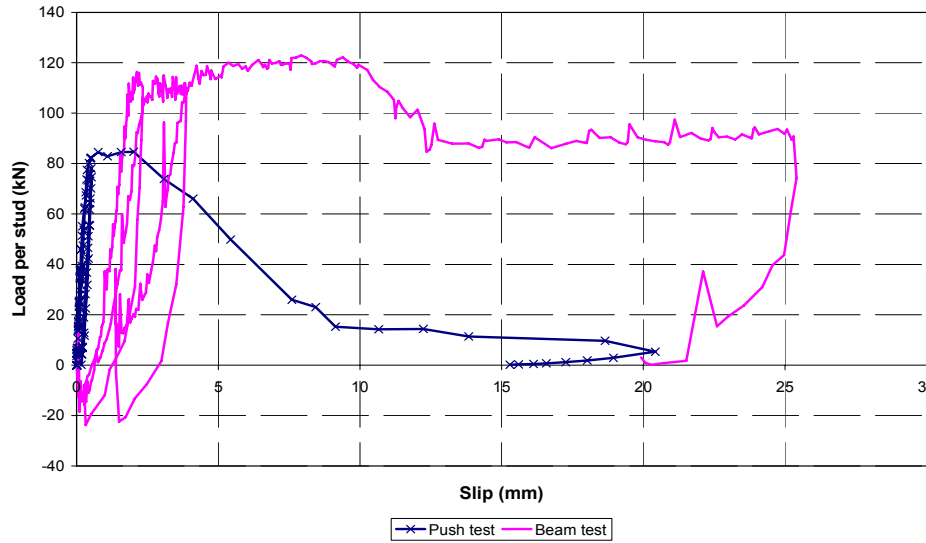

$$n_r = 1$$

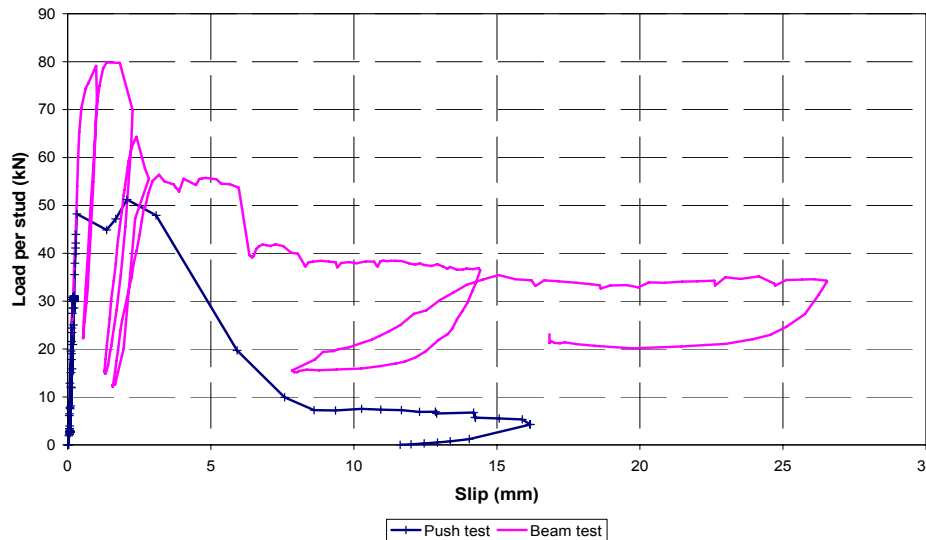

$$n_r = 2$$

Back-breaking failure

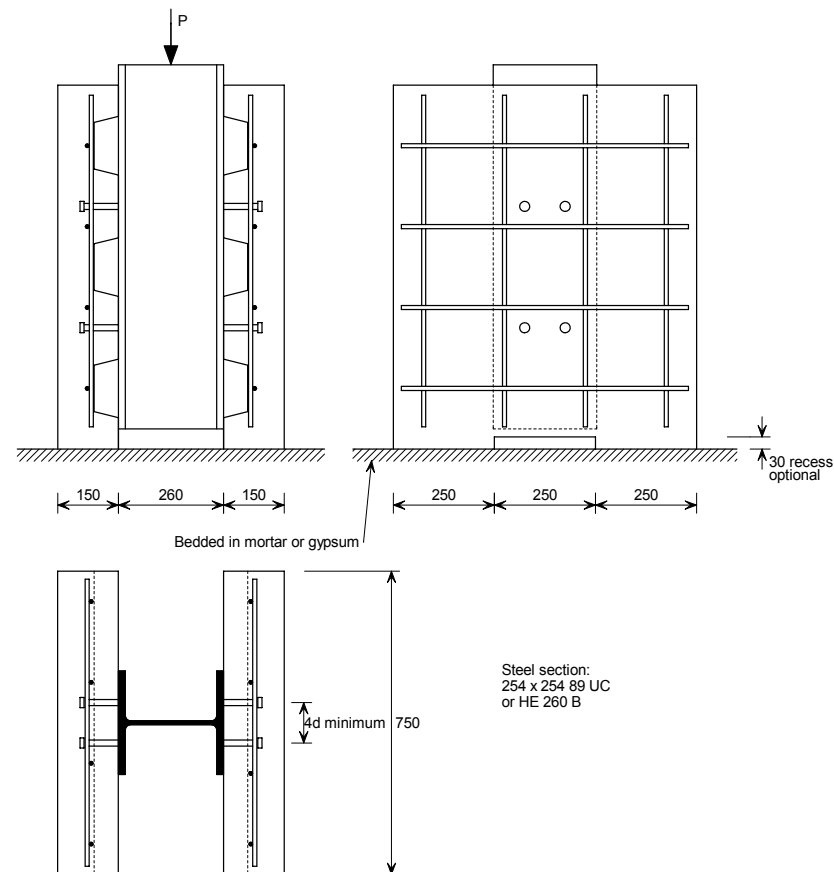
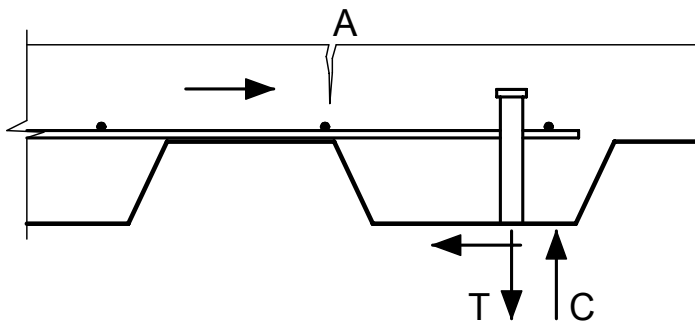



<http://www.access-steel.com/>

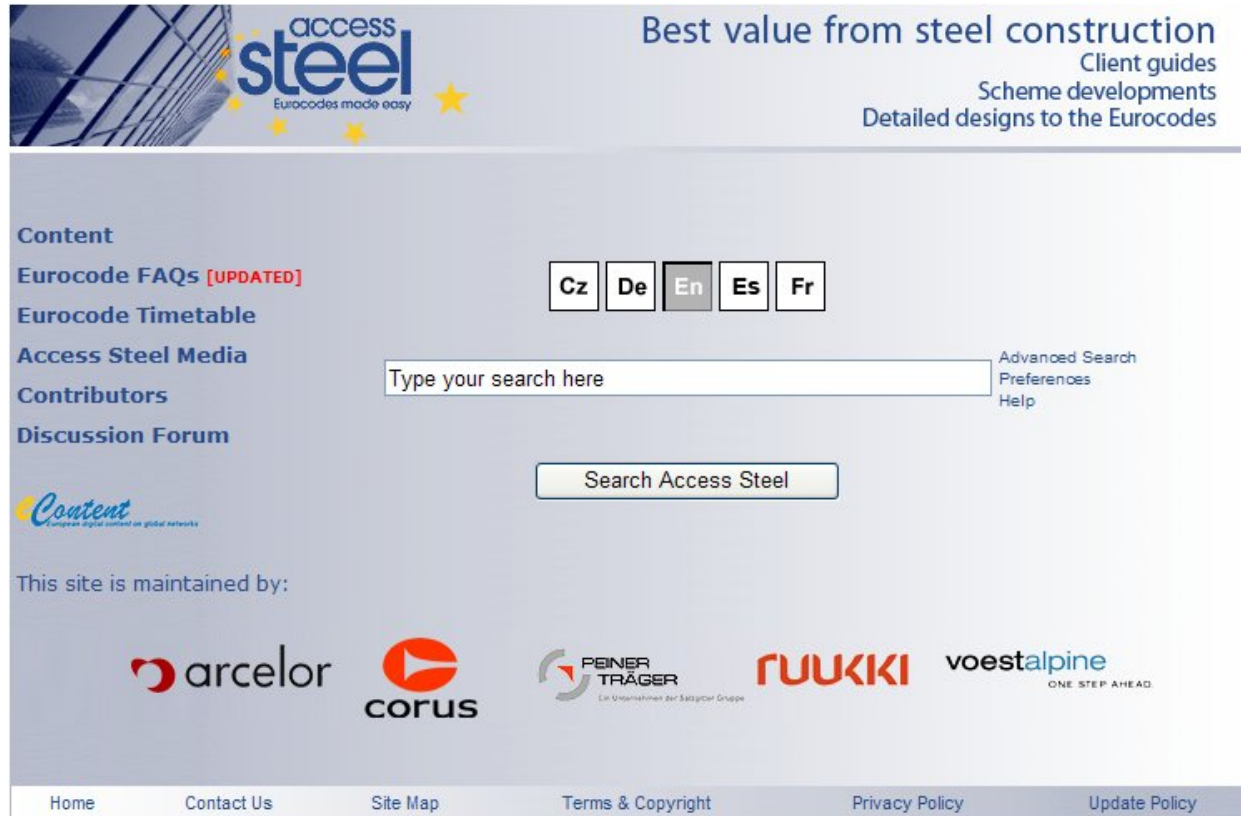

The screenshot shows the homepage of the Access Steel website. At the top left is the 'access steel' logo with the tagline 'Eurocodes made easy'. To the right, it says 'Best value from steel construction' and lists 'Client guides', 'Scheme developments', and 'Detailed designs to the Eurocodes'. Below this is a navigation menu with links for 'Content', 'Eurocode FAQs [UPDATED]', 'Eurocode Timetable', 'Access Steel Media', 'Contributors', and 'Discussion Forum'. There are language selection buttons for 'Cz', 'De', 'En', 'Es', and 'Fr', with 'En' selected. A search bar contains the text 'Type your search here' and a 'Search Access Steel' button. To the right of the search bar are links for 'Advanced Search', 'Preferences', and 'Help'. At the bottom, it says 'This site is maintained by:' followed by logos for 'arcelor', 'corus', 'PEINER TRÄGER', 'RUUKKI', and 'voestalpine'. A footer contains links for 'Home', 'Contact Us', 'Site Map', 'Terms & Copyright', 'Privacy Policy', and 'Update Policy'.

s.hicks@steel-sci.com