



Workshop “Eurocodes: background and applications”

Brussels, 18-20 February 2008

Design of pile foundations following Eurocode 7-Section 7

Roger FRANK, Professor

Ecole nationale des ponts et chaussées, Paris



- Section 1 General
- Section 2 Basis of geotechnical design
- Section 3 Geotechnical data
- Section 4 Supervision of construction, monitoring and maintenance
- Section 5 Fill, dewatering, ground improvement and reinforcement
- **Section 6 Spread foundations**
- **Section 7 Pile foundations**
- Section 8 Anchorages
- **Section 9 Retaining structures**
- Section 10 Hydraulic failure
- Section 11 Site stability
- Section 12 Embankments

EUROPEAN STANDARD	EN 1997-1
NORME EUROPÉENNE	
EUROPÄISCHE NORM	November 2004

ICS 91.120.20 Supersedes ENV 1997-1:1994

English version

Eurocode 7: Geotechnical design - Part 1: General rules

Eurocode 7: Calcul géotechnique - Partie 1: Règles générales Eurocode 7: Entwurf, Berechnung und Bemessung in der Geotechnik - Teil 1: Allgemeine Regeln

This European Standard was approved by CEN on 23 April 2004.

CEN members are bound to comply with the CEN/CENELEC Internal Regulations which stipulate the conditions for giving this European Standard the status of a national standard without any alteration. Up-to-date lists and bibliographical references concerning such national standards may be obtained on application to the Central Secretariat or to any CEN member.

This European Standard exists in three official versions (English, French, German). A version in any other language made by translation under the responsibility of a CEN member into its own language and notified to the Central Secretariat has the same status as the official versions.

CEN members are the national standards bodies of Austria, Belgium, Cyprus, Czech Republic, Denmark, Estonia, Finland, France, Germany, Greece, Hungary, Iceland, Ireland, Italy, Latvia, Lithuania, Luxembourg, Malta, Netherlands, Norway, Poland, Portugal, Slovakia, Slovenia, Spain, Sweden, Switzerland and United Kingdom.



EUROPEAN COMMITTEE FOR STANDARDIZATION
COMITÉ EUROPÉEN DE NORMALISATION
EUROPÄISCHES KOMITEE FÜR NORMUNG

Management Centre: rue de Stassart, 35 B-1050 Brussels

© 2004 CEN. All rights of exploitation in any form and by any means reserved worldwide for CEN national Members. Ref. No. EN 1997-1:2004 E



EN 1997-1:

- E A simple semi-empirical method for bearing resistance estimation
- H Limiting foundation movements and structural deformation

EN 1997-2:

- D.7 Example of a method to determine the compressive resistance of a single pile (CPT)
- D.6 Example of a correlation between compressive resistance of a single pile and cone penetration resistance
- E.3 Example of a method to calculate the compressive resistance of a single pile (PMT)

- **Pile load tests**
- **Axially loaded piles**
 - ULS compressive or tensile resistance ('bearing capacity')
 - Vertical displacements of pile foundations: serviceability of the supported structure
- **Transversely loaded piles**
- **Structural design of piles**

Need to take into account the **actions due to ground displacement** :

- downdrag (negative skin friction)
- heave
- transverse loading

- * the design values of the **strength and stiffness** of the moving ground should usually be **upper values**
- * the **ground displacement is treated as an action** and an interaction analysis is carried out,
or
- * an upper bound of the **force transmitted by the ground** is introduced as the design action.



(1)P The design shall be based on one of the following approaches:

- the results of static load tests, which have been demonstrated, by means of calculations or otherwise, to be consistent with other relevant experience;
- empirical or analytical calculation methods whose validity has been demonstrated by static load tests in comparable situations;
- the results of dynamic load tests whose validity has been demonstrated by static load tests in comparable situations;
- the observed performance of a comparable pile foundation, provided that this approach is supported by the results of site investigation and ground testing.



(1)P Pile load tests shall be carried out in the following situations:

- when using a type of pile or installation method for which there is no comparable experience;
- when the piles have not been tested under comparable soil and loading conditions;
- when the piles will be subject to loading for which theory and experience do not provide sufficient confidence in the design. The pile testing procedure shall then provide loading similar to the anticipated loading;
- when observations during the process of installation indicate pile behaviour that deviates strongly and unfavourably from the behaviour anticipated on the basis of the site investigation or experience, and when additional ground investigations do not clarify the reasons for this deviation.



7.5.2.1 Loading procedure

(1)P The pile load test procedure⁵, particularly with respect to the number of loading steps, the duration of these steps and the application of load cycles, shall be such that conclusions can be drawn about the deformation behaviour, creep and rebound of a piled foundation from the measurements on the pile. For trial piles, the loading shall be such that conclusions can also be drawn about the ultimate failure load.

(4) Pile load tests for the purpose of designing a tensile pile foundation should be carried out to failure. Extrapolation of the load-displacement graph for tension tests should not be used.



7.6.1 General

7.6.1.1 Limit state design

(1)P The design shall demonstrate that exceeding the following limit states is sufficiently improbable:

- ultimate limit states of compressive or tensile resistance failure of a single pile;
- ultimate limit states of compressive or tensile resistance failure of the pile foundation as a whole;
- ultimate limit states of collapse or severe damage to a supported structure caused by excessive displacement or differential displacements of the pile foundation;
- serviceability limit states in the supported structure caused by displacement of the piles.



ULS Compressive or tensile resistance of piles (bearing capacity)



ULS - From static load test results

7.6.2.2 Ultimate compressive resistance from static load tests

(8)P For structures, which do not exhibit capacity to transfer loads from "weak" piles to "strong" piles, as a minimum, the following equation shall be satisfied:

$$R_{c;k} = \text{Min} \left\{ \frac{(R_{c;m})_{\text{mean}}}{\xi_1}, \frac{(R_{c;m})_{\text{min}}}{\xi_2} \right\} \quad (7.2)$$

where ξ_1 and ξ_2 are correlation factors related to the number of piles tested and are applied to the mean $(R_{c;m})_{\text{mean}}$ and the lowest $(R_{c;m})_{\text{min}}$ of $R_{c;m}$ respectively.

NOTE The values of the correlation factors may be set by the National annex. The recommended values are given in Table A.9.



Characteristic resistance from measured resistances

Table A.9 - Correlation factors ξ to derive characteristic values from static pile load tests (n - number of tested piles)

ξ for $n =$	1	2	3	4	≥ 5
ξ_1	1,40	1,30	1,20	1,10	1,00
ξ_2	1,40	1,20	1,05	1,00	1,00

ULS – From ground test results : ‘Model pile’ method

7.6.2.3 Ultimate compressive resistance from ground test results

(5)P The characteristic values $R_{b;k}$ and $R_{s;k}$ shall either be determined by:

$$R_{c;k} = (R_{b;k} + R_{s;k}) = \frac{R_{b;cal} + R_{s;cal}}{\xi} = \frac{R_{c;cal}}{\xi} = \text{Min} \left\{ \frac{(R_{c;cal})_{\text{mean}}}{\xi_3}, \frac{(R_{c;cal})_{\text{min}}}{\xi_4} \right\} \quad (7.8)$$

where ξ_3 and ξ_4 are correlation factors that depend on the number of profiles of tests, n , and are applied respectively: to the mean values $(R_{c;cal})_{\text{mean}} = (R_{b;cal} + R_{s;cal})_{\text{mean}} = (R_{b;cal})_{\text{mean}} + (R_{s;cal})_{\text{mean}}$ and to the lowest values $(R_{c;cal})_{\text{min}} = (R_{b;cal} + R_{s;cal})_{\text{min}}$,

NOTE The values of the correlation factors may be set by the National annex. The recommended values are given in Table A.10.



Characteristic resistance from calculated resistances

Table A.10 - Correlation factors ξ to derive characteristic values from ground test results (n - the number of profiles of tests)

ξ for $n =$	1	2	3	4	5	7	10
ξ_3	1,40	1,35	1,33	1,31	1,29	1,27	1,25
ξ_4	1,40	1,27	1,23	1,20	1,15	1,12	1,08



ULS – From ground test results : 'Alternative' method

7.6.2 3 Ultimate compressive resistance from ground test results

(8) The characteristic values may be obtained by calculating:

$$R_{b;k} = A_b q_{b;k} \quad \text{and} \quad R_{s;k} = \sum_i A_{s;i} \cdot q_{s;i;k} \quad (7.9)$$

where $q_{b;k}$ and $q_{s;i;k}$ are characteristic values of base resistance and shaft friction in the various strata, obtained from values of ground parameters.

NOTE If this alternative procedure is applied, the values of the partial factors γ_b and γ_s recommended in Annex A may need to be corrected by a model factor larger than 1,0. The value of the model factor may be set by the National annex.



ULS - Permanent and transient design situations - Load factors

Recommended values for γ_F on actions or effects of actions (from *Table A.3 of Annex A* in EN 1997-1)

Action		DA1-1 (B)	DA1-2 (C) *	DA2	DA3 **
Permanent	unfavourable γ_G	1,35	1,0	1,35	1,35
	favourable	1,0	1,0	1,0	1,0
Variable	Unfavourable γ_Q	1,5	1,3	1,5	1,5
	favourable	0	0	0	0

* the partial factors are applied to the ground strength parameters.

** values for structural actions only ; for geotechnical actions, the partial factors are applied to the ground strength parameters.



ULS - Permanent and transient design situations - Resistance factors

Recommended values for γ_b , or γ_s and γ_t (from *Tables A.6, A.7 and A.8 of Annex A* in EN 1997-1)

	Design Approach 1						DA 2	DA3*
	Combination 1			Combination 2				
Type of pile	γ_b	γ_s	γ_t	γ_b	γ_s	γ_t	$\gamma_b = \gamma_s = \gamma_t$	$\gamma_b = \gamma_s = \gamma_t$
<u>Compression</u>								
Driven	1.0	1.0	1.0	1.3	1.3	1.3	1.1	1.0
Bored	1.25	1.0	1.15	1.6	1.3	1.5	1.1	1.0
CFA	1.1	1.0	1.1	1.45	1.3	1.4	1.1	1.0
<u>Tension</u>								
γ_{st}		1,25			1,6		1,15	1,1

* for D.A 3 : partial coefficients are applied to soil parameters. DA 3 is not applicable when the resistance is derived from pile load tests.



Characteristic value :

$$R_k = R / \xi \quad \text{where } R = \gamma_{Rd} R_{cal} \text{ or } R = R_m \quad (1)$$

Design value :

$$R_d = R_k / \gamma_t \quad \text{or } R_d = R_{bk} / \gamma_b + R_{sk} / \gamma_s \quad (2)$$

Applied compression/tension **load** :

$$F_d = \gamma_F F_k \quad (3)$$

General condition for ULS being :

$$F_d \leq R_d \quad (4)$$

equations (1) to (4) lead to :

$$F_k \leq R / \gamma_F \cdot \gamma_t \cdot \xi = R / FS \quad (5)$$



Piles in compression :

(3)P For piles in groups, two failure mechanisms shall be taken into account:

- compressive resistance failure of the piles individually;
- compressive resistance failure of the piles and the soil contained between them acting as a block.

The design resistance shall be taken as the lower value caused by these two mechanisms.

Piles in tension :

(3)P For tension piles, two failure mechanisms shall be considered:

- pull-out of the piles from the ground mass;
- uplift of the block of ground containing the piles.

(4)P Verification against uplift failure of the block of ground containing the piles (see Figure 7.1), shall be carried out in accordance with 2.4.7.4.

(5) For isolated tensile piles or a group of tensile piles, the failure mechanism may be governed by the pull-out resistance of a cone of ground, especially for piles with an enlarged base or rock socket.

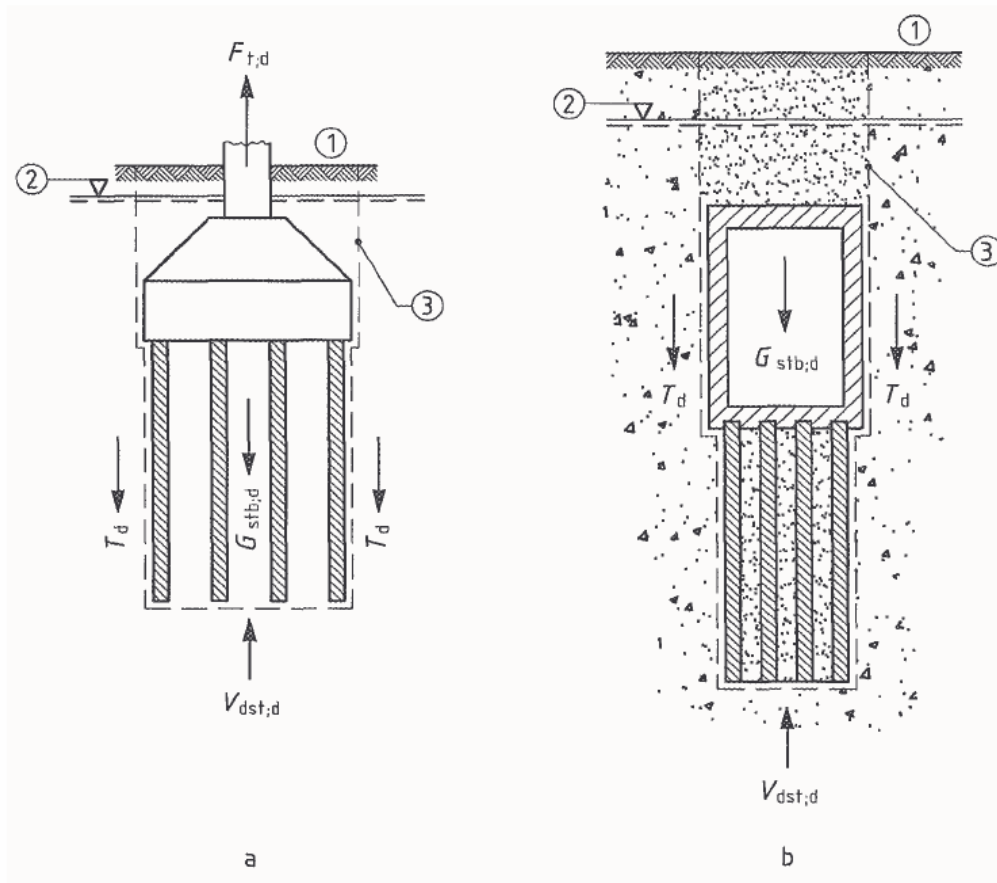

- 1 ground surface
- 2 ground-water level
- 3 side of the 'block', where resistance T_d develops

Figure 7.1 — Examples of uplift (UPL) of a group of piles



Vertical displacements of pile foundations (serviceability of supported structure)

Vertical displacements under SLS conditions must be assessed and checked against limiting value :

* Piles in compression

- downdrag must be taken into account
- settlement due to group action must be taken into account

* Piles in tension

- check upward displacements in the same manner

Example from pile load test results (Orr, 2005)

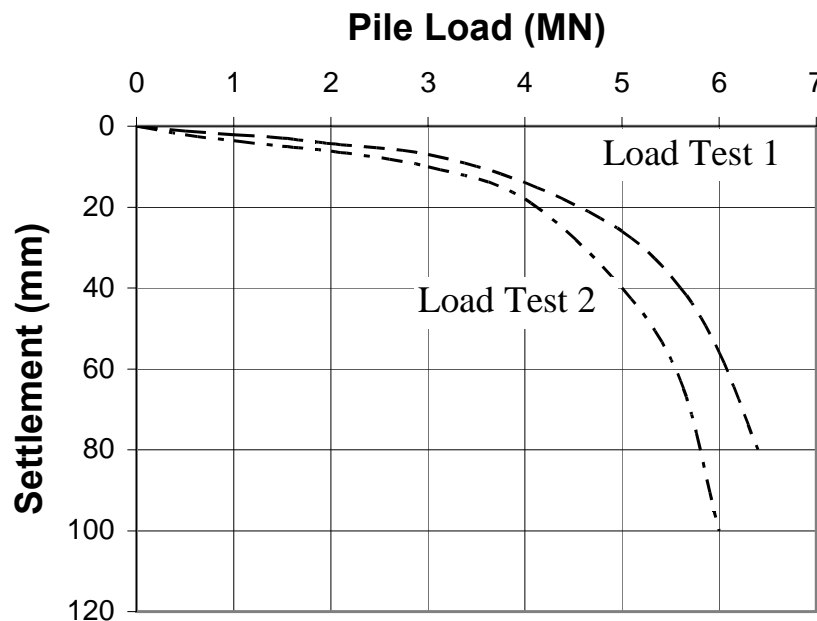

Pile Load Test Results

Load (MN)	Settlement Pile 1 (mm)	Settlement Pile 2 (mm)
0	0	0
0.5	2.1	1.2
1.0	3.6	2.1
1.5	5.0	2.9
2.0	6.2	4.1
3.0	10.0	7.0
4.0	18.0	14.0
5.0	40.0	26.0
5.6	63.0	40.0
6.0	100.0	56.0
6.4		80.0

- driven piles $B = 0.40$ m $D = 15.0$ m
- allowable settlement is 10 mm
- loads : $G_k = 20,000$ kN and $Q_k = 5,000$ kN



- From Table, for $n = 2$ pile load tests : for $n = 2$ pile load tests : $\xi_1 = 1.30$ and $\xi_2 = 1.20$

- $R_k = \text{Min}\{5.3/1.30; 5.0/1.20\} = \text{Min}\{4.08; 4.17\} = 4.08$

DA 1-2 : $F_d = 26.5$ MN and $R_d = 3.14$ MN.

9 piles are needed (neglecting group effects)

&

DA1-1 : $F_d = 34.5$ MN and $R_d = 4.08$

9 piles are also needed (neglecting group effects)

DA 2 : $F_d = 34.5$ MN and $R_d = 3.71$ MN

10 piles are needed (neglecting group effects).

- * $G_k + Q_k = 25 \text{ MN}$
- * load per pile : through analysis of the 2 load curves for $s < 10 \text{ mm}$
- * Same analysis as for ULS ($\xi_1 = 1.30$ and $\xi_2 = 1.20$)
leads to $R_k = \text{Min}\{3.25/1.30; 3.0/1.20\}$
 $= 2.5 \text{ MN}$
- * thus, 10 piles are needed (neglecting group effects)



Adequate safety against failure (ULS)

$$F_{tr} \leq R_{tr}$$

One of the following failure mechanisms should be considered :

- short piles : rotation or translation as a rigid body**
- for long slender piles : bending failure of the pile with local yielding and displacement of the soil near the top of the pile**



Transverse resistance R_{tr} :

- * from head transverse displacement pile load test
- * from ground tests results and pile strength parameters

The theory of beams with subgrade reaction moduli can be used

The following must be taken into account:

- **non linear soil : $E(\varepsilon)$**
- **flexural stiffness of the piles : EI**
- **fixity conditions (connections)**
- **group effect**
- **load reversals and cyclic loading**



Designing pile foundations with Eurocode 7 :

- * importance of static pile load tests
- * an innovative approach to pile capacity taking account of number of load tests or number of soil profiles
- * need of assessing serviceability of structures through displacement calculations



Thank you for your attention !