



RAILWAY ACTIONS. SELECTED CHAPTERS FROM EN 1991-2 AND ANNEX A2 OF EN 1990

Dr. h. c. Marcel Tschumi



Actions on structures – Traffic loads on bridges

Foreword

Section 1

General

Section 2

Classification of actions

Section 3

Design situations

Section 4

Road traffic actions and other actions specifically for road bridges

Section 5

Actions on footways, cycle tracks and footbridges

Section 6

Rail traffic actions and other actions specifically for railway bridges



Actions on structures – Traffic loads on bridges

Annex A (I)	Models of special vehicles for road bridges
Annex B (I)	Fatigue life assessment for road bridges. Assessment method based on recorded traffic
Annex C (N)	Dynamic factors $1+\varphi$ for real trains
Annex D (N)	Basis for the fatigue assessment of railway structures
Annex E (I)	Limits of validity of load model HSLM and the selection of the critical universal train from HSLM-A
Annex F (I)	Criteria to be satisfied if a dynamic analysis is not required
Annex G (I)	Method for determining the combined response of a structure and track to variable actions
Annex H (I)	Load models for rail traffic loads in transient situations



Basis of structural design – Application for bridges

Section A2.1 Field of application

Section A2.2 Combinations of actions

A2.2.1 General

A2.2.2 ...for road bridges

A2.2.3 ...for footbridges

A2.2.4...for railway bridges

A2.2.5

Section A2.3 Ultimate limit states

Section A2.4 Serviceability limit states

A2.4.1 General

A2.4.2 ...serviceability criteria for road bridges

A2.4.3 ...serviceability criteria for footbridges

A2.4.4 serviceability criteria for railway bridges

S : gauge
U : cant
Q_s: noising force

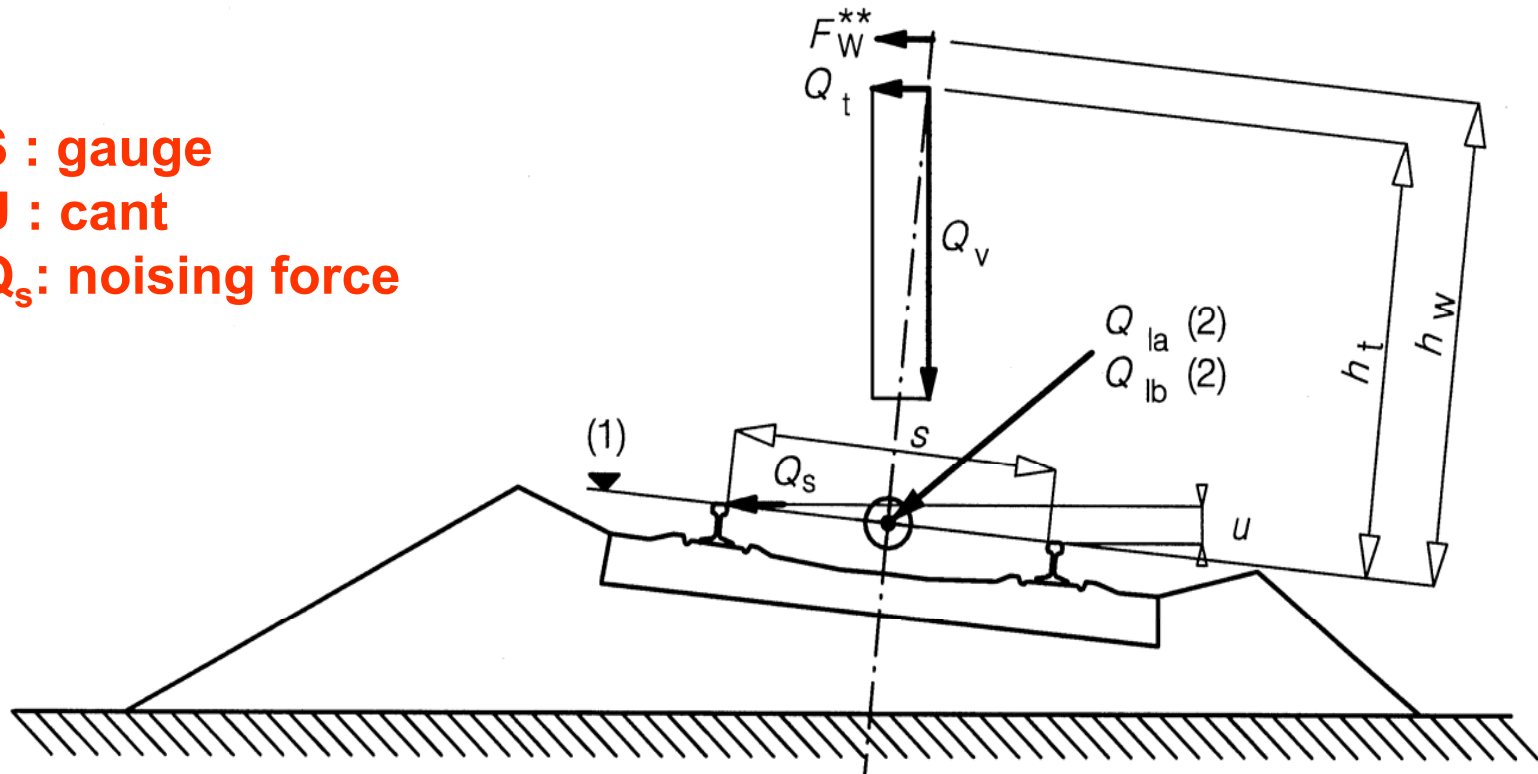

- (1) Running surface
- (2) Longitudinal forces acting along the centreline of the track

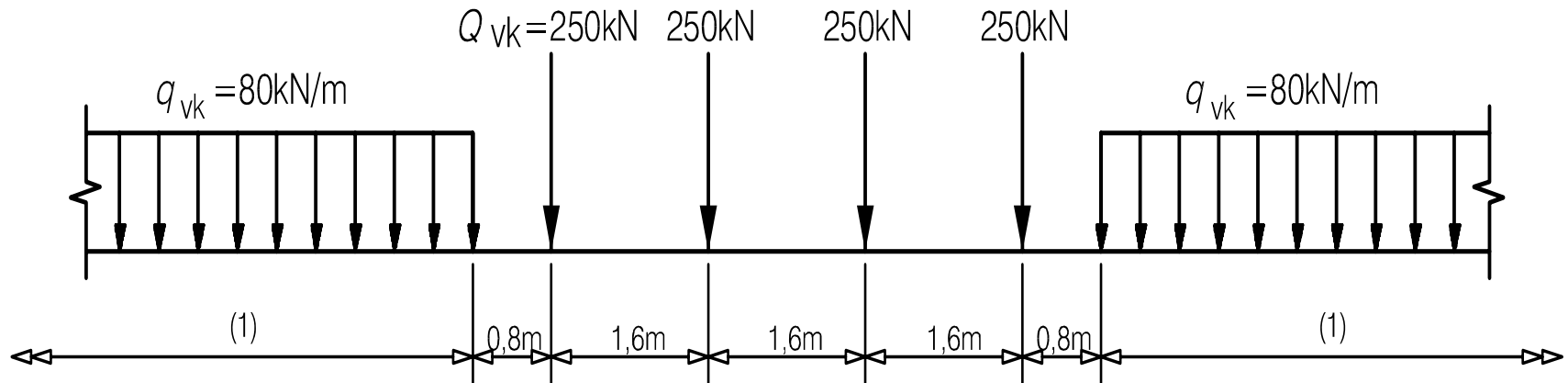

The characteristic values given in this figure shall be multiplied by a factor α on lines carrying rail traffic which is heavier or lighter than normal rail traffic. When multiplied by the factor α , the loads are called "classified vertical loads". This factor α shall be one of the following: 0,75 - 0,83 - 0,91 - 1,00 - 1,10 - 1,21 - **1,33** - 1,46.

The value 1,33 is normally recommended on lines for freight traffic and international lines (UIC CODE 702, 2003).

The actions listed below shall be multiplied by the same factor α :

centrifugal forces

nosing force

traction and braking forces

load model SW/0 for continuous span bridges



2 of 6
examples
of real
service
trains

①

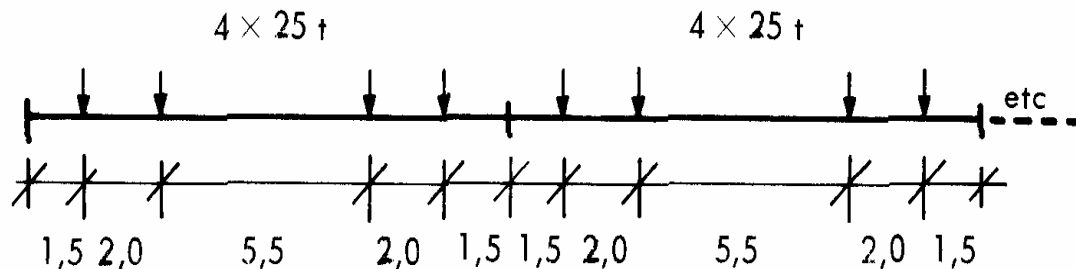

②

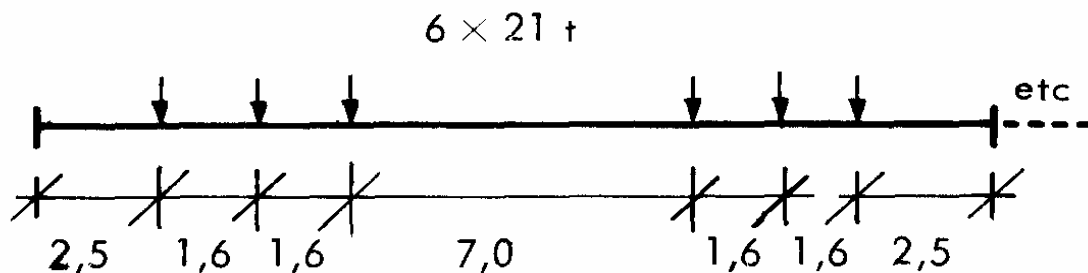

$$(1 + \varphi) S_{\text{real trains } 1-6} \leq \Phi S_{\text{LM71}}$$

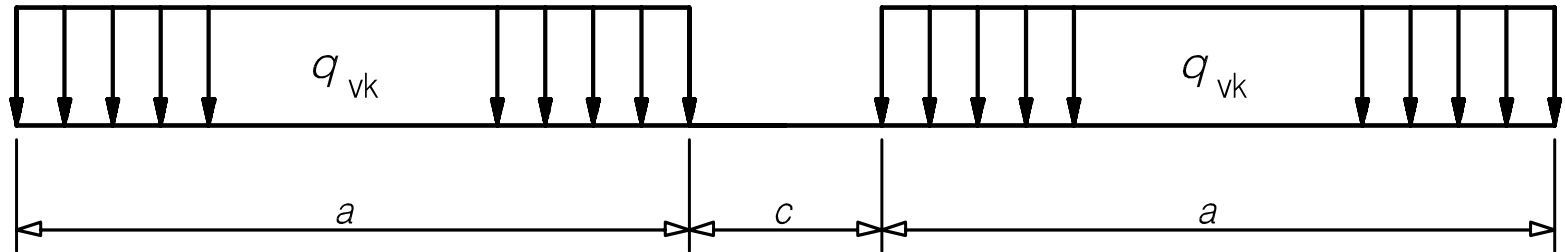

Load model	q_{vk} [kN/m]	a [m]	c [m]
SW/0	133	15,0	5,3
SW/2	150	25,0	7,0



Example of a heavy weight waggon

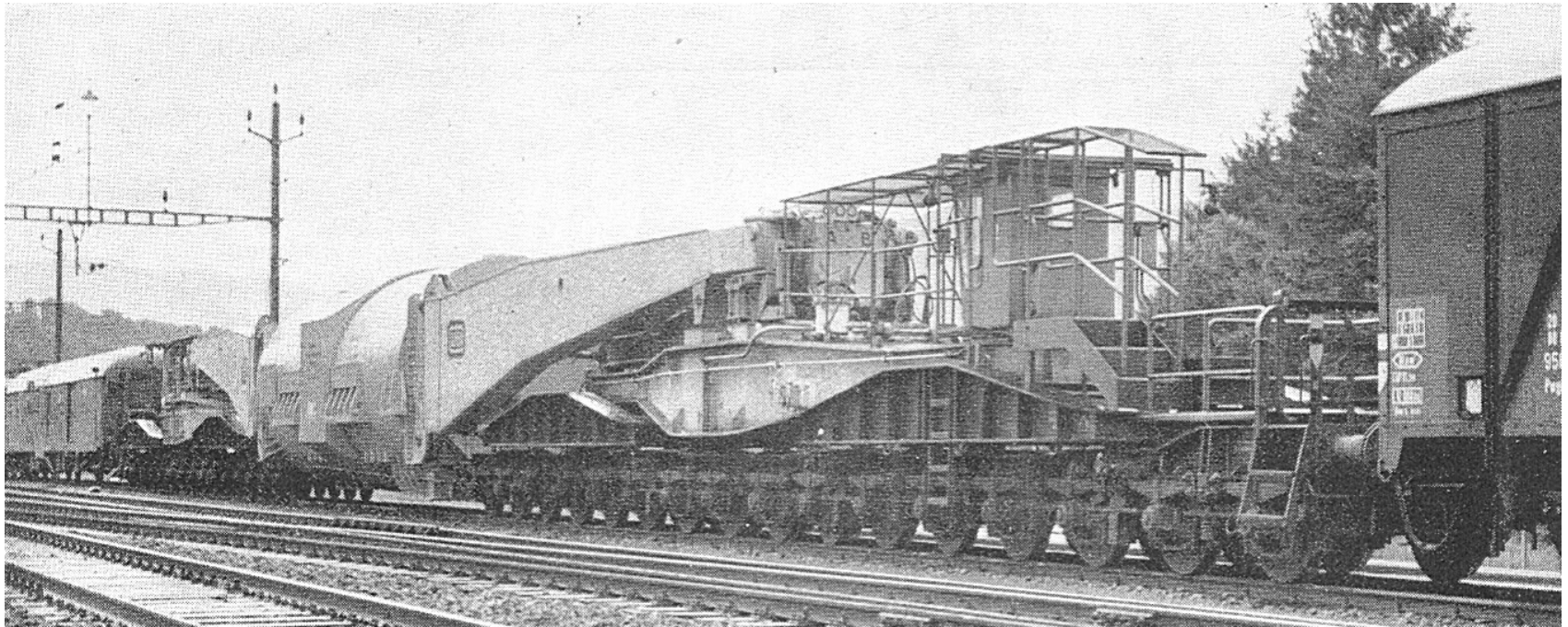

Wagon DB with 32 axles, selfweight 246 t, cantilevers included, pay load 457 t, mass per axle 22 t , $l_{\text{tot}} = 63,3 \text{ m}$

**α x LM71 (and SW/2 where required),
without dynamic factor, uniformly
distributed over a width of 3,00 m at a
level 0,70 m below the running surface
of the rail.**



- the speed of traffic across the bridge,
- the span L of the element,
- the mass of the structure,
- the natural frequencies of the whole structure and relevant elements of the structure,
- the number of axles, axle loads and the spacing of axles,
- the damping of the structure,
- vertical irregularities in the track,
- the unsprung/sprung mass and suspension characteristics of the vehicle,
- the presence of regularly spaced supports of the deck slab (cross girders),
- vehicle imperfections (wheel flats, out of round wheels, etc.),
- the dynamic characteristics of the track (ballast, sleepers, track components etc.).



Dynamic factors (6.4.5.2) for static calculations:

Φ_2 for carefully maintained track

Φ_3 for standard track (means:poor track)

The dynamic factor Φ , which enhances the static load effects under Load Models LM 71, LM SW/0 and LM SW/2, is taken as either Φ_2 or Φ_3 , according to the quality of track maintenance . The dynamic factors Φ_2 et Φ_3 are calculated on the basis of formulae based on a value called determinant length $L\Phi$ given in Table 6.2 of the Eurocode. If no dynamic factor is specified Φ_3 shall be used.



- **Dynamic enhancement for real trains**

$$1 + \varphi = 1 + \varphi' + (1/2) \varphi''$$

- **Dynamic enhancement for fatigue calculations**

$$\varphi = 1 + 1/2(\varphi' + (1/2)\varphi'')$$

- **Dynamic factor $\Phi_2(\Phi_3)$ for static calculations
(determinant lengths L_Φ due to table 6.2)**

- **Dynamic enhancement for dynamic studies**

$$\varphi'_{dyn} = \max \left| y_{dyn} / y_{stat} \right| - 1$$



The freedom for the choice of the factor α could provoke a non homogeneous railway network in Europe! Therefore in UIC Leaflet 702 (2003) $\alpha = 1,33$ is generally recommended for all new bridges constructed for the international freight network, unfortunately not obligatory!

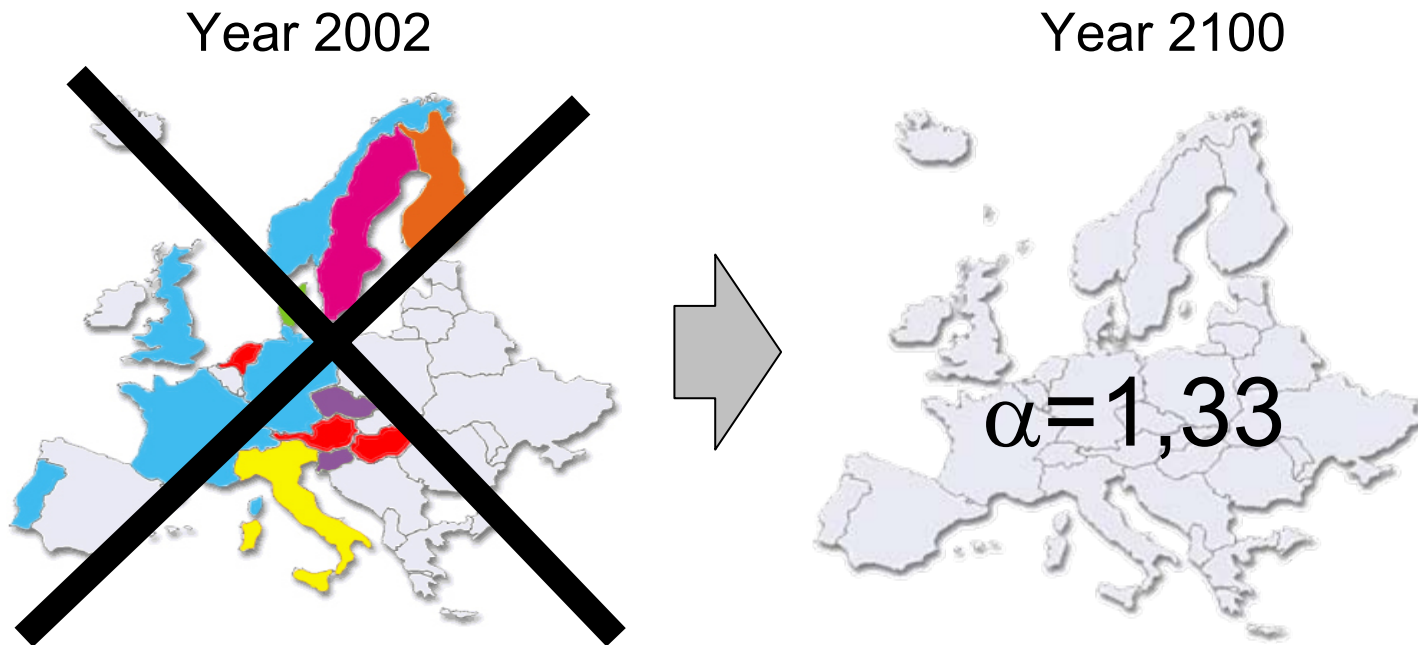



ULS:

For **new bridges** it should absolutely be adopted

$$\alpha = 1,33.$$

Fatigue:

All calculations are done with the Load Model 71 and the factor

$$\alpha = 1,00.$$



Existing bridges

The question of updated rail traffic actions is currently studied within the European Research Project « Sustainable Bridges - Assessment for Future Traffic Demands and longer Lives».

See: www.sustainablebridges.net



Serviceability Limit States (SLS) Interaction track – bridge:

Theoretically this is a Serviceability Limit State (SLS) for the bridge and an Ultimate Limit State (ULS) for the rail. But as the given permissible rail stresses and deformations were obtained by deterministic design methods, calibrated on the existing practice, the calculations for interaction have to be done – in contradiction to EN1991-2, where there is a mistake - always with $\alpha = 1,00!!$

Serviceability Limit States (SLS) Permissible vertical deflections:

To check the permissible vertical deflection with a severe formula given later for speeds less than 200 km/h, to minimise track maintenance and to avoid dynamic studies (note: more stiffness costs nothing when doing calculations with LCC),

$$\alpha = 1,00$$

shall be adopted, even if $\alpha = 1,33$ is taken into consideration for ULS.



Due to UIC CODE 700		Mass per axle				
		A	B	C	D	E
Mass per m = p		16t	18t	20t	22,5t	25t
1	5 t/m	A	B1			
2	6,4 t/m		B2	C2	D2	
3	7,2 t/m			C3	D3	
4	8 t/m			C4	D4	E4
5	8,8 t/m					E5

Increase of costs in % due to $\alpha = 1,33$, related to those calculated with $\alpha = 1,0$ / bridges **built with traffic interference** (ERRI D 192/RP 4, 1996):

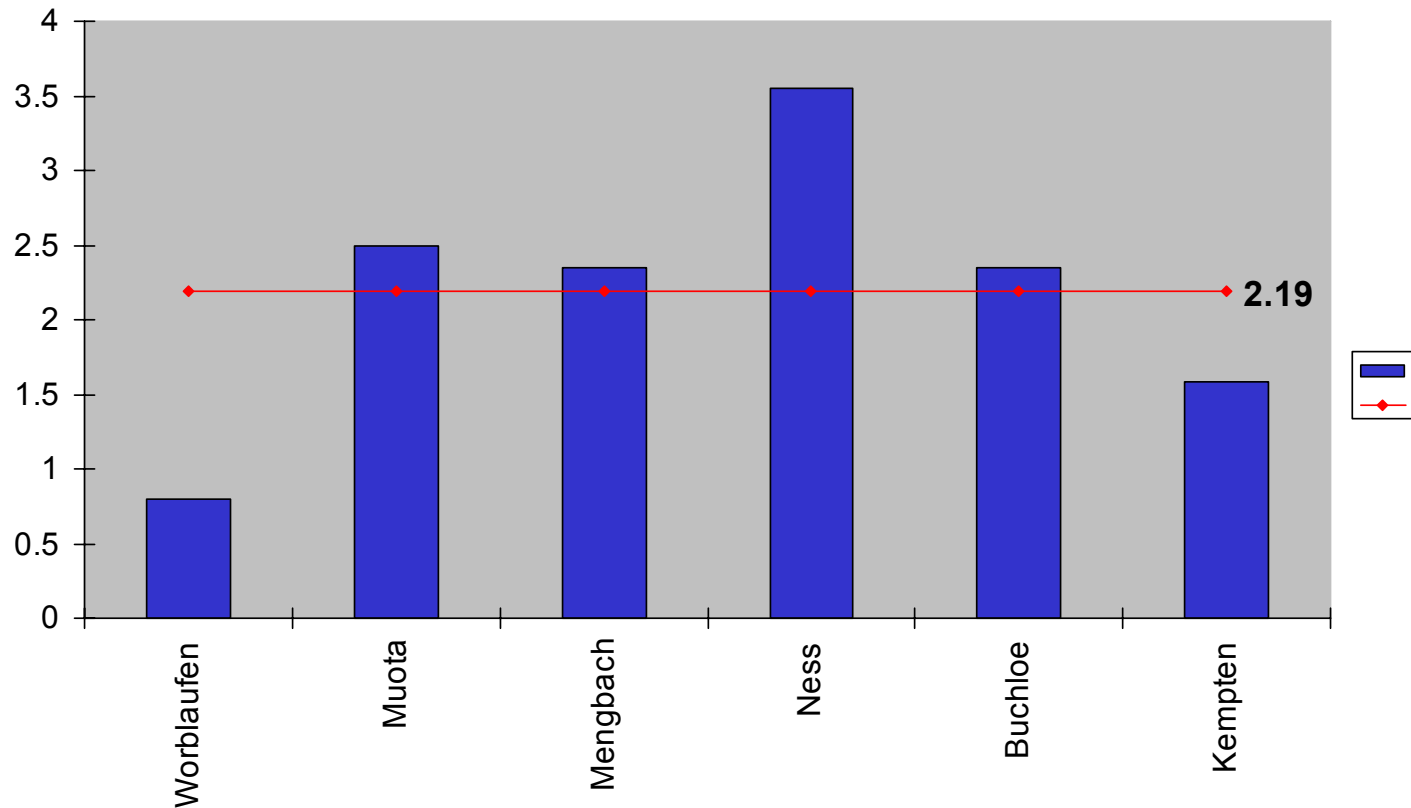



Increase of costs in % due to $\alpha = 1,33$, related to those calculated with $\alpha = 1,0$ / bridges **built without traffic interference**,
(ERRI D 192/RP 4, 1996):

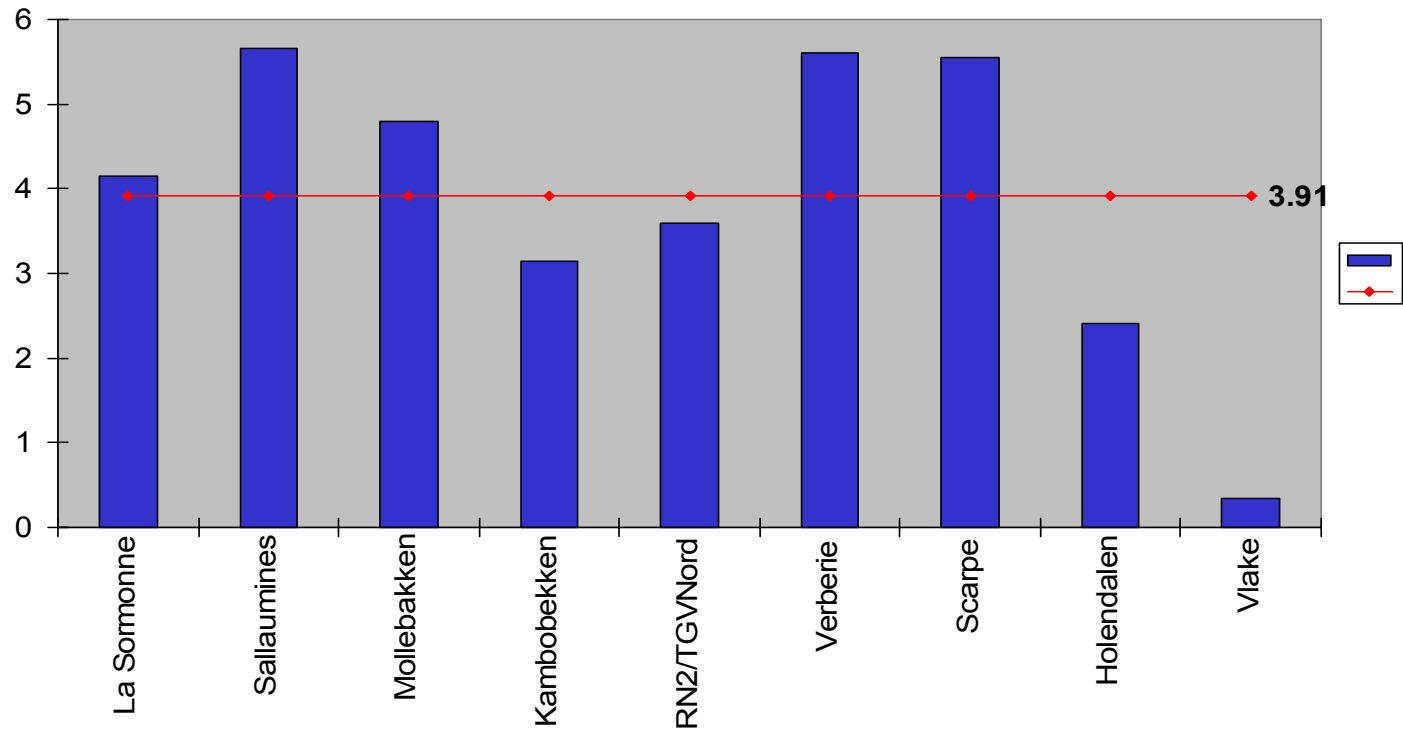

Relative displacements of the track and of the bridge, caused by the combination of the effects of **thermal variations, train braking and traction forces, as well as deflection of the deck under vertical traffic loads (LM 71)**, lead to the track/bridge phenomenon that results in additional stresses to the bridge and the track.
Take LM 71 with $\alpha = 1.00$ (even if $\alpha > 1.00$ for ULS)!

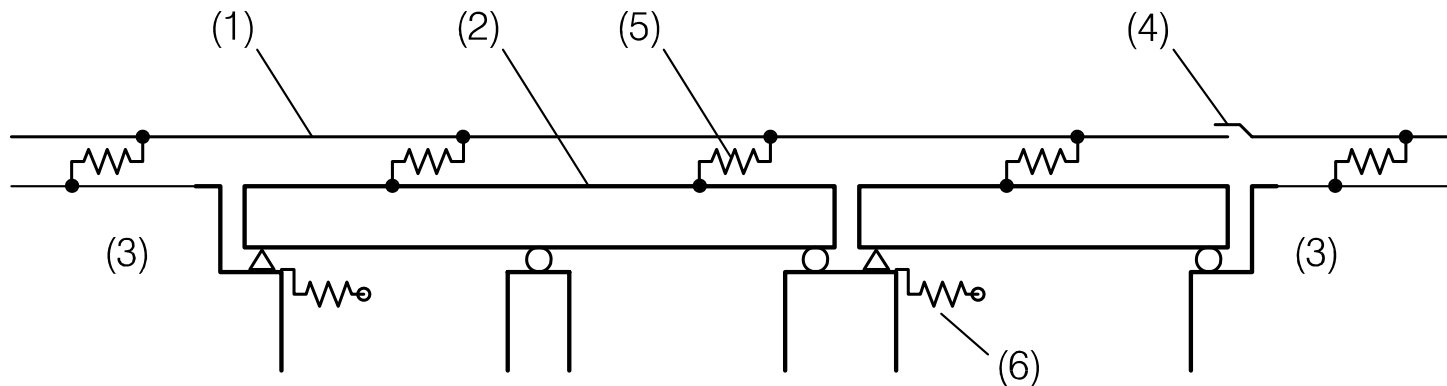



Practice with rail UIC 60, steel grade giving at least 900 N/mm² strength, minimum curve radius $r \geq 1500$ m, laid on ballasted track with concrete sleepers and consolidated, > 30 cm deep ballast, the permissible additional stresses in continuous welded rail on the bridge due to interaction is:

compression:	72 N/mm²
traction:	92 N/mm²



Examples of expansion lengths

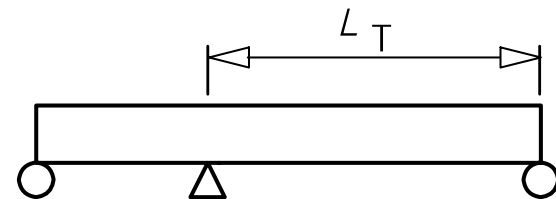
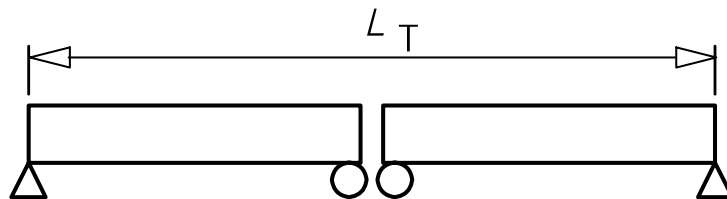
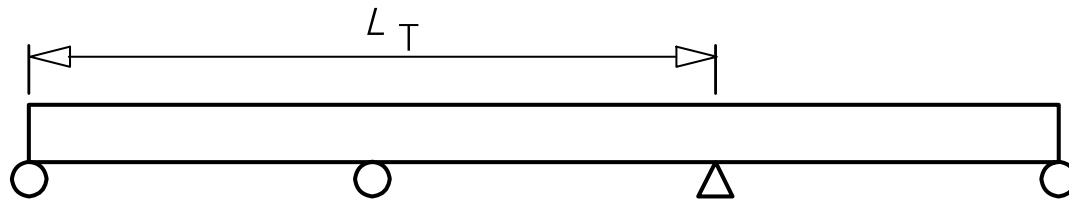
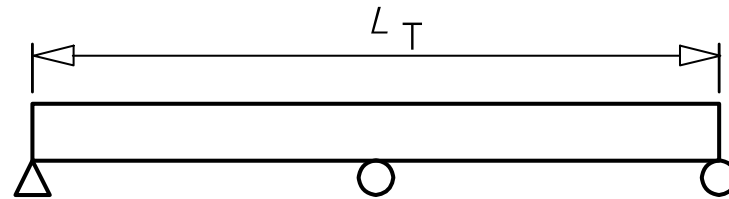

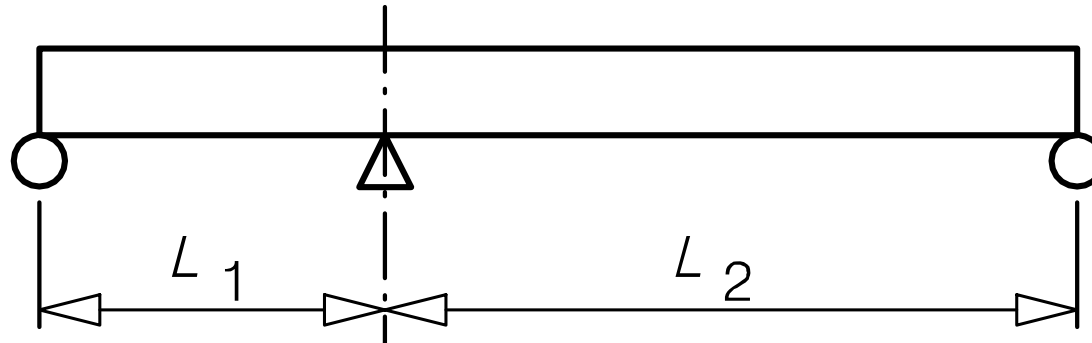

Remark: The decks corresponding to L_1 or to L_2 may have additional supports.

L_1 max. or L_2 max. without expansion joints:

- 90 m (concrete, composite)
- 60 m (steel),

but:

$L_1 + L_2 = 180$ m/ 120 m with fixed bearing in the middle !!!!!



For new bridges
even if taking $\alpha = 1,33$ for ULS design –
note: a slightly oversized bridge for ULS
has less fatigue problems if the loadings do not
increase!) - fatigue assessments are done
with the load model LM 71 and $\alpha = 1,00$.
In supplement, the calculation of the damage
equivalent factors for fatigue λ should be done with
the heavy traffic mix, that means waggon with 25t
(250kN) axles, in accordance with Annex D of
EN 1991-2



$$\gamma_{Ff} \lambda \Phi_2 \Delta \sigma_{71} \leq \frac{\Delta \sigma_c}{\gamma_{Mf}}$$

γ_{Ff} is the partial safety factor for fatigue loading

λ is the damage equivalence factor for fatigue which takes account of the service traffic on the bridge and the span of the member. Values of λ are given in the design codes.

Φ_2 is the dynamic factor (see 6.4.5 of EN 1991-2)

$\Delta \sigma_{71}$ is the stress range due to the Load Model 71 (and where required SW/0) but with $\alpha = 1$, the loads being placed in the most unfavourable position for the element under consideration.

$\Delta \sigma_c$ is the reference value of the fatigue strength (see EN 1993)

γ_{Mf} is the partial safety factor for fatigue strength in the design codes

Example of a train (no 1 of 12 given types of trains):

$$\Sigma Q = 6630\text{kN} \quad V = 200\text{km/h} \quad L = 262,10\text{m} \quad q = 25,3\text{kN/m'}$$

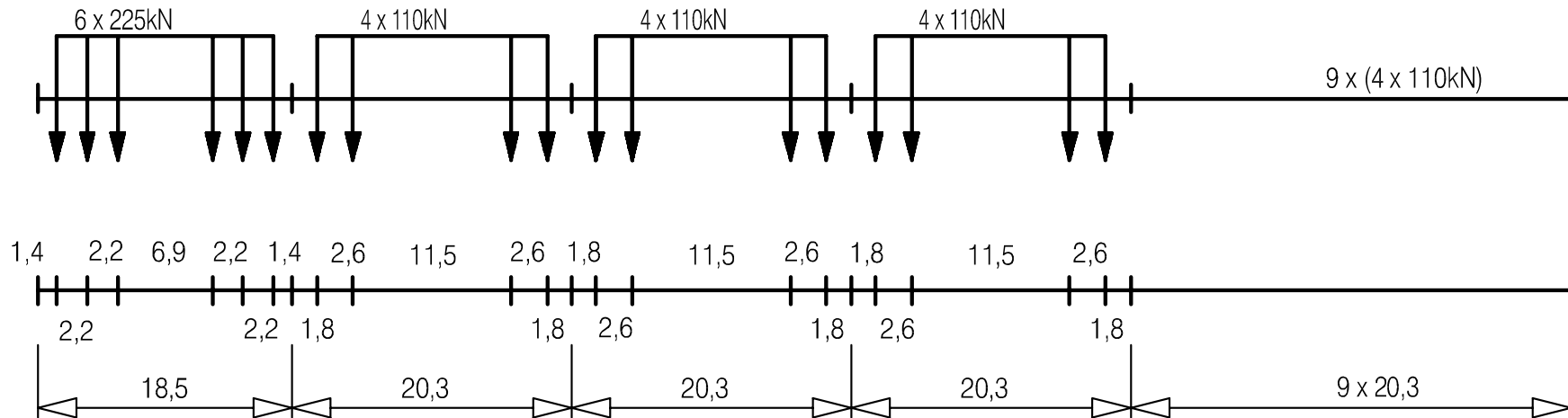



λ is the damage equivalence factor for fatigue which takes account of the span, the service traffic, the annual traffic volume, the intended design life of the structural element and the number of tracks.

$$\lambda = \lambda_1 \lambda_2 \lambda_3 \lambda_4$$

where:

λ_1 is a factor accounting for the structural member type (e.g. a continuous beam) and takes into account the damaging effect of the chosen service traffic (e.g. heavy traffic mix), depending on the length of the influence line or area.

λ_2 is a factor that takes into account the annual traffic volume.

λ_3 is a factor that takes into account the intended design life of the structural member.

λ_4 is a factor which denotes the effect of loading from more than one track.

Values of λ are given in the design codes.

General:

It cannot be stressed often enough that railway bridges must be designed and constructed in a fatigue-resistant way. For having optimal Life Cycle Costs (LCC) and for reaching the intended design life of minimum 100 years, all important structural members shall be designed for fatigue!

Rules for steel bridges:

Constructional details have to be chosen and found which give the maximum possible fatigue detail categories $\Delta\sigma_c$, e.g.:

Composite girders:

detail category 71

Welded plate girders:

detail category 71

Truss bridges:

**detail category 71 at sites where fatigue is a risk /
detail category 36 at sites where fatigue is no risk.**



Rules for reinforced bridges:

- **For reinforced railway bridges the fatigue strength categories $\Delta\sigma$ must of course be observed.**
- **Welded joints of reinforcing bars should be avoided in principle in regions with high stress variation.**
- **The bending radii of reinforcing bars must be big enough to avoid too much loss of fatigue strength.**

Rules for prestressed bridges:

- **Fully prestressed bridges under service loads have no fatigue problems. For not fully prestressed bridges under service loads the permissible stress $\Delta\sigma_s$ must be observed as well for the prestressing steel as for the reinforcing bars.**
- **Plastic ducts can increase fatigue resistance of prestressing steel and electrically isolated tendons permit to assure the quality with long term monitoring.**
- **Anchorage and couplers for prestressing tendons have to be placed such that they are in a region of low stress variation.**

Personal advice:

Bridge competitions should be carried out in two phases. The first phase should be anonymous with only few calculations and plans called for. The second phase should however not be anonymous. In this phase it is essential, from the owner's point of view, that recommendations for the important aspects of the design are provided. These include avoiding, where ever possible, expansion joints in the rails near the bridge and, very important, excluding poor constructional details which will lead to fatigue problems.



Permissible deflections

In **EN 1990, Annex A2 [2]** only minimum conditions for bridge deformations are given. The rule **does not take into account track maintenance**. A simplified rule for permissible deflections is given below for trains and speeds up to 200km/h, to avoid the need for excessive track maintenance. In addition, this simplified rule has the advantage, that no dynamic analysis is necessary for speeds less than 200km/h. For all classified lines with $\alpha > 1,0$, that means **also if $\alpha = 1.33$ is adopted for ULS**, the following permissible values for deflections are recommended, **always calculated** under LM71 “+” SW/O, multiplied by Φ , and **with $\alpha = 1.0$** :

$V < 80$ km/h

$$\delta_{\text{stat}} \leq l / 800^*$$

***Note:** Due to what is said in see A.2.4.4.2.3 [2], namely that the maximum total deflection measured along any track due to rail traffic actions should not exceed $L/600$, please note that 600 multiplied with 1,33 gives approximately 800.

$80 \leq V \leq 200$ km/h

$$\delta_{\text{stat}} \leq l / (15V - 400)^{**}$$

**** Note:** The upper limit $l/2600$ for 200 km/h is the permissible deflection which DB has taken during many years for designing bridges for high speed lines in Germany, with satisfactory results. It is also the formula which you can find in the Swiss Codes (SIA 260).

$V > 200$ km/h

The value determined by the dynamic study, but min. $\delta_{\text{stat}} \leq l / 2600$



Collapse of railway bridge over the river Birs in Münchenstein, Switzerland, the 14th June 1891, by buckling of the upper flange under an overloaded train, 73 persons were killed, 131 persons more or less injured. => Tetmajers law.